



**INSTANT RECOVERY®
GAS FRYER
SERIES 2009**

MANUAL

IMPORTANT:

THE USER'S MANUAL PROVIDES SPECIFIC OPERATING INSTRUCTIONS FOR YOUR MODEL. USE THE INSTANT RECOVERY® GAS FRYER ONLY AS INSTRUCTED IN THIS MANUAL.

KEEP A COPY OF YOUR BILL OF SALE.

The date on the bill establishes the warranty period should service be required. If service is performed, it is in your interest to obtain and keep all receipts.

KEEP THIS MANUAL FOR TRAINING NEW PERSONNEL.

Record the Serial number and Model number of this Instant Recovery® Gas Fryer in the spaces provided. **Keep these numbers for future reference.**

SERIAL NUMBER

MODEL NUMBER

Keating commercial fryers are not intended for household use.

As continuous product improvement occurs, specifications may be changed without notice.

1-800-KEATING | keatingofchicago.com

NOTE:

PURCHASER SHOULD POST IN A PROMINENT LOCATION INSTRUCTIONS TO BE FOLLOWED IN THE EVENT THE USER SMELLS GAS. THIS INFORMATION SHALL BE OBTAINED BY CONSULTING THE LOCAL GAS SUPPLIER.



⚠ WARNING

Improper installation, adjustment, alteration, service or maintenance can cause property damage, injury or death. Read the installation, operating and maintenance instructions thoroughly before installing or servicing this equipment.



FOR YOUR SAFETY:

Do not store or use gasoline or other flammable vapors or liquids in the vicinity of this or any other appliance.

⚠ WARNING

IF NOT INSTALLED, OPERATED AND MAINTAINED IN ACCORDANCE WITH THE MANUFACTURER'S INSTRUCTIONS, THIS PRODUCT COULD EXPOSE YOU TO SUBSTANCES IN FUEL OR IN FUEL COMBUSTION WHICH CAN CAUSE DEATH OR SERIOUS ILLNESS AND WHICH ARE KNOWN TO THE STATE OF CALIFORNIA TO CAUSE CANCER, BIRTH DEFECTS OR OTHER REPRODUCTIVE HARM.

⚠ WARNING

PROPANE GAS MAY EVENTUALLY LOSE ITS ODOR AND PRECAUTIONS SHOULD BE TAKEN TO ASSURE THAT PROPANE GAS IS NOT PRESENT EVEN THOUGH YOU DO NOT DETECT AN ODOR. IF THERE IS ANY DOUBT, YOU SHOULD CALL YOUR LOCAL PROPANE GAS SUPPLIER FOR ASSISTANCE.

THE EQUIPMENT IS TO BE INSTALLED TO COMPLY WITH THE BASIC PLUMBING CODE OF THE BUILDING OFFICIALS AND CODE ADMINISTRATORS INTERNATIONAL, INC. (BOCA) AND THE FOOD SERVICE SANITATION MANUAL OF THE FOOD AND DRUG ADMINISTRATION (FDA).



■ TABLE OF CONTENTS

Important Safety Instructions	i	Cooking	9
INTRODUCTION	1	Timer Programming	10
INSTALLATION		Oil Breakdown	10
Damage During Shipment	1	Draining.....	10
Drop-In Fryer Counter Cut-Out/Installation	2	Cleaning and Boil-Out	11 - 13
FIRST STEPS		OPERATOR SELF HELP CHECK LIST	13
Positioning	3	PREVENTATIVE MAINTENANCE	
Ventilation	3	Preventive Maintenance Chart	13
National Code Requirement	3	Hi-Limit Check Bi-Monthly.....	13
Leveling.....	3	Thermostat Calibration	13
Restraining Devices.....	3 - 4	Thermostat Bulb Positioning.....	14
Gas Connectors & Pipe Size.....	4	WARRANTY REPAIRS	15
Electrical Connection	4	Troubleshooting.....	16 - 18
Flexible Gas Connection & Quick Disconnect Devices.....	5	Ordering Parts.....	18
PLACING YOUR KEATING FRYER IN OPERATION		Parts List.....	19 - 32
Filling	5	Wiring Diagrams	33 - 49
Lighting	5 - 9	Warranty Information	50
Shutdown	6 - 9		

■ INTRODUCTION

Instructions in this manual should be read thoroughly before attempting to operate this Keating Gas Fryer. All installation and service on Keating equipment must be performed by qualified, certified, licensed and/or authorized installation or service personnel.

Operating information for Keating equipment has been prepared for use by qualified and/or authorized personnel.

Keating equipment is made in the USA and has American sizes of hardware. All metric conversions are approximate.

■ INSTALLATION INSTRUCTIONS

Proper installation will assure top performance. Alterations of any kind to your equipment will void the warranty. Before uncrating, check equipment carefully for damage.

IF EQUIPMENT ARRIVES DAMAGED

Keating does not assume responsibility for loss or damage incurred in transit.

IMPORTANT

This merchandise has been thoroughly inspected and carefully packed before leaving our plant. Responsibility for its safe delivery was assumed by the carrier at the time of shipment. Claims for loss or damage to the contents should, therefore, be made upon the carrier, as follows:

CONCEALED LOSS OR DAMAGE

Concealed loss or damage means loss or damage which does not become apparent until the merchandise has been unpacked. The contents may be damaged in transit due to rough handling even though

the carton may not show external damage. When the damage is discovered upon unpacking, make a written request for inspection by the carrier's agent within fifteen days of the delivery date. Then file a claim with the carrier since such damage is the carrier's responsibility. By following these instructions carefully, we guarantee our full support of your claims to protect you against loss from concealed damage.

VISIBLE LOSS OR DAMAGE

Any external evidence of loss or damage must be noted on the freight bill or express receipt, and signed by the carrier's agent. Failure to adequately describe such external evidence of loss or damage may result in the carrier refusing to honor a damage claim. The form required to file such a claim will be supplied by the carrier.

DO NOT RETURN DAMAGED MERCHANDISE TO KEATING. FILE YOUR CLAIM AS STATED ABOVE.

FIRST STEPS

POSITIONING

Keep appliance area free and clear of any combustibles. Position the Keating Gas Fryer 6 inches (152mm) from any combustible material. A minimum of 24 inches (610mm) should be provided at the front of the Keating Gas Fryer for servicing and proper operation. Air for combustion enters the fryer from the bottom of the cabinet and the bottom of the control panel.

DO NOT BLOCK BOTTOM OF KEATING INSTANT RECOVERY® GAS FRYER CABINET. DO NOT OBSTRUCT FLUE.

Your Keating Instant Recovery® Gas Fryer is designed to be serviced from the front.

MINIMUM CLEARANCE

CONSTRUCTION CLEARANCES		
	COMBUSTIBLE	NON-COMBUSTIBLE
BACK	6"	0"
RIGHT SIDE	6"	0"
LEFT SIDE	6"	0"

SUITABLE FOR NON-COMBUSTIBLE FLOORS

VENTILATION

The Keating Gas Fryer must be installed in an area providing adequate air supply and ventilation. Do not obstruct the flow of combustion and ventilation air. Proper ventilation is one of the important considerations for efficient operation of the Keating Gas Fryer. It should be installed so that the products of combustion are removed efficiently without producing drafts that will interfere with proper burner operation. The intake for the exhaust fan should not be placed close to the flue of the Keating Gas Fryer to insure proper air flow necessary for combustion. The area around the front and bottom of the Keating Gas Fryer must be kept clear and unobstructed. In the USA, the ventilation systems must conform to the ANSI/NFPA96 latest edition. "A minimum of 18" (457mm) should be maintained between the flue outlet and the lower edge of the grease filters." Must be installed at least 16" away from any open flame. It is the responsibility of the owner and the local installer to comply with national and local codes.

NATIONAL CODE REQUIREMENT

The installation must conform with local codes, or in the absence of local codes, with the National Fuel Gas code, ANSI Z223.1 or the Natural gas Installation Code, CAN/CGA-B149.1 or the Propane Installation Code, CAN/CGA-B149.2. Flexible connectors must comply to ANSI Z221.69/CAN/CGA1.16. Keating

equipment is designed and manufactured to operate only on the type of gas specified by the user and indicated on the serial plate located inside the door. The gas may be natural, propane or manufactured. The type of gas cannot be converted to another gas fuel by turning or engaging a switch.

LEVELING

The fryer will operate at its highest efficiency when properly leveled. Place a level on fryer vessel from side to side. For fryers on legs, the bottom foot of the leg is adjustable. Turn counter clockwise to decrease height or clockwise to increase height until level. For fryers on casters, the casters are adjustable by loosening the jam nut and turning the caster in or out. When the desired level is reached, tighten the jam nut. Adjustments of more than 3/4" are not recommended on any caster. The same procedure should be followed to level the fryer from front to back.

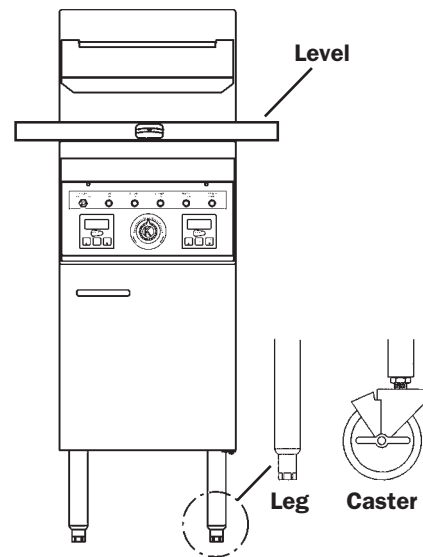

RESTRAINING DEVICES

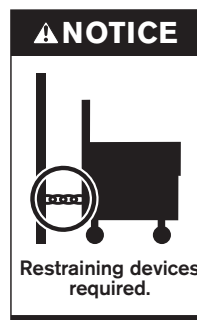

1. Adequate means must be provided to limit the movement of the appliance without depending on the connector and the quick-disconnect device or its associated piping to limit the appliance movement.

Fryer must also be restrained to prevent tipping when installed so that hot liquid splashing is avoided.

2. The restraint means must be attached to the rear of the Keating Gas Fryer within 2" of the center line width and approximately 1-5/8" from the bottom of the cabinet back to allow the restraining bolt to be anchored to the cabinet back between the cabinet bottom and inner liner.

NOTE: The installer is responsible for attaching the tipping restraint. See page 2 for drop-in installation.

If disconnection of the restraint is necessary, it must be reconnected when the Keating Gas Fryer is returned to its originally installed position.

NOTICE: WHEN THIS APPLIANCE IS INSTALLED WITH CASTERS, IT MUST BE INSTALLED WITH CASTERS SUPPLIED, A CONNECTOR COMPLYING WITH EITHER ANSI Z21.69 OR CAN/CGA-6.16 AND A QUICK-DISCONNECT DEVICE COMPLYING WITH EITHER ANSI Z21.41 OR CSA-6.9. IT MUST ALSO BE INSTALLED WITH RESTRAINING MEANS TO GUARD AGAINST TRANSMISSION OF STRAIN TO THE CONNECTOR, AS SPECIFIED IN THE APPLIANCE MANUFACTURER'S INSTRUCTIONS.

ELECTRICAL CONNECTION

The Keating fryer, when installed, must be electrically grounded in accordance with local codes, or in the absence of local codes, the National Electrical Code, ANSI/NFPA No. 70. or the Canadian Electrical Code, CSAC-22.2 as applicable. A wiring diagram is located on the last page. In the USA and Canada, the electrical supply must be 120 VAC, 60 Hz.

The Keating Instant Recovery® Gas Fryer is equipped with a 9' neoprene covered, 3 wire electrical cord with a three-pronged grounded plug for protection against electrical shock.

NOTE: The electrical wiring diagram for the fryer is located on the inside of the fryer door or in the back of this manual.

⚠ WARNING

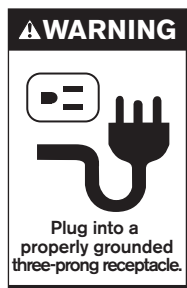

THIS APPLIANCE IS EQUIPPED WITH A THREE-PRONG 120 VOLT NEMA 5-15 (GROUNDING) PLUG FOR YOUR PROTECTION AGAINST SHOCK HAZARD AND SHOULD BE PLUGGED DIRECTLY INTO A PROPERLY GROUNDED AND POLARIZED THREE-PRONG RECEPTACLE. DO NOT CUT OR REMOVE THE GROUNDING PRONG FROM THIS PLUG.

⚠ CAUTION

Before plugging in the fryer, confirm the outlet is properly polarized and grounded. If the hot and neutral terminals are reversed or the outlet is not properly grounded, the burners may not ignite (burner on light will go out after 2-1/2 seconds and the ignition processes will continue 3 times).

GAS CONNECTIONS AND PIPE SIZE

A single Keating Gas Fryer requires a standard gas pipe size of 3/4 inch (19mm) I.D. connection. Multiple fryers with a common manifold will require a minimum of 1 1/4 inch I.D. gas supply line. The size of the gas supply pipe is very important. If the pipe is too small you will have low gas pressure at the Keating Gas Fryer manifold. Low gas pressure will cause slow recovery and/or delayed ignition, amongst other problems. If you have a question about gas pipe size, call your local gas company.

⚠ CAUTION

Before connecting new pipe to the Keating Gas Fryer the pipe must be blown out to remove all foreign particles. These particles in the controls or burners may cause improper or dangerous operating conditions.

⚠ CAUTION

Pipe joint compounds that are used on threaded joints of appliance piping shall be resistant to the action of liquefied petroleum gases (Loctite PST 56765). When using pipe joint compound do not apply to the first two threads. Use only a very small amount and only on male threads. This will prevent clogging of burner orifices and the gas valve. Never use compound on female threads as it might be pushed into the gas valve.

Have your installer check for gas leaks using a soap and water solution before operating.

⚠ WARNING

DO NOT USE AN OPEN FLAME TO CHECK FOR GAS LEAKS

1. The Keating Gas Fryer and its individual shut off valves must be disconnected from the gas supply piping system during any pressure testing of that system at test pressures in excess of 1/2 psi (3.45kPa) (13.84 in WC). High pressure can damage the gas valve causing a hazardous condition. Excessive pressure introduced to the fryer may void the warranty.

2. The appliance must be isolated from the gas supply piping system by closing its individual manual shutoff valve during any pressure testing of

the gas supply piping system at test pressures equal to or less than 1/2 psi (3.45 kPa).

NOTE: Keating fryers use a constant pilot that will emit a very small amount of gas at all times.

NOTE: Line pressure must be kept below 10" (Nat), 13" (LP) during leak test to avoid damage to the gas valve.



If more than one gas unit is on the same supply line, you may require a larger line. Consult your local gas company to assure adequate volume and pressure. Refer to serial plate for proper gas requirement for your particular model.

FLEXIBLE GAS CONNECTORS AND QUICK DISCONNECT DEVICES

For an appliance equipped with casters:

The installation shall be made with a connector that complies with the Standard for Connectors for Movable Gas Appliances, ANSI Z21.69 or the Standard for Connectors for Moveable Gas Appliances, CAN/CGA-6.16, and a quick disconnect device that complies with the Standard for Quick-Disconnect Devices for Use With Gas Fuel, ANSI Z21.41 or the Standard for Quick Disconnect Devices for Use with Gas Fuel, CAN1-6.9.

⚠️ WARNING

NEVER LEAVE YOUR FRYER OPERATING UNATTENDED.

(When all previous instructions have been completed).

Check the serial plate on the panel (inside cabinet) to determine if the burner is set up for the proper type gas before connecting the quick-disconnect or piping from the building gas supply pipe.

- a. Maximum **INCOMING** gas pressure
 - NATURAL GAS – 7 inches W.C. with burners on
 - LP GAS – 11 inches W.C. with burners on
- b. Fryer **MANIFOLD** gas pressure
 - NATURAL GAS – 4 inches W.C. with burners on
 - LP – 10 inches W.C. with burners on

⚠️ WARNING

ALWAYS disconnect fuel source and power supply before servicing.

NEVER move a fryer when full of oil.

NEVER introduce objects or liquids into fryer, while operational, which are not designed or made for cooking.

THIS FRYER MAY NOT BE ALTERED, MODIFIED OR CHANGED IN ANY WAY.

NOTE: It is estimated that half of all service calls made on Keating Instant Recovery® Fryers result from an inadequate gas supply. During installation, have a gas company representative make certain that the fryer is receiving adequate gas pressure and volume (see “Installation” or your serial plate on the fryer door).

⚠️ WARNING

PROPANE GAS MAY EVENTUALLY LOSE ITS ODOR AND PRECAUTIONS SHOULD BE TAKEN TO ASSURE THAT IT IS NOT PRESENT EVEN THOUGH YOU DO NOT DETECT AN ODOR. IF THERE IS ANY DOUBT, YOU SHOULD CALL YOUR LOCAL PROPANE GAS SUPPLIER FOR ASSISTANCE.

■ OPERATING

FILLING

NOTE: Before filling the fryer make certain the fryer vessel is sanitized, dry and the drain valve is completely closed.

NOTE: Solid shortening can not be used in a Keating Model AA Gas Fryer. If solid shortening is used, it should be melted prior to filling the fryer vessel. Damage done by melting solid shortening in the fryer vessel will void the warranty.

⚠️ WARNING

BE SURE THE HEAT TRANSFER TUBES ARE COMPLETELY COVERED WITH OIL BEFORE SWITCHING THE FRYER ON. IF OIL LEVEL DROPS BELOW TOP OF HEAT TRANSFER TUBES, SEVERE DAMAGE TO FRYER AND INJURY TO OPERATOR MAY RESULT.

⚠️ WARNING

WATER IN ANY FORM AND HOT OIL DON'T MIX!

⚠️ CAUTION

OIL EXPANDS WHEN HEATED. THE MAX LEVEL LINE HAS BEEN PROVIDED TO ENSURE OPTIMUM COOKING WHILE ENSURING THE SAFETY OF THE OPERATOR. DO NOT OVERFILL THE FRYER VESSEL.

Figure 1
MAX Level Line

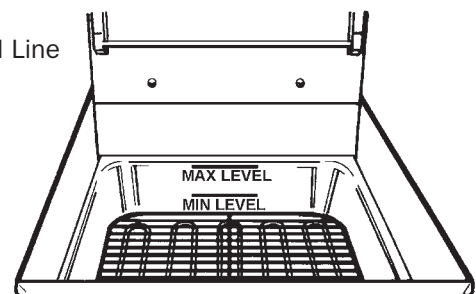

Fill the fryer vessel with oil or MELTED solid shortening up to the “Max” line.

LIGHTING

⚠️ WARNING

BEFORE ATTEMPTING TO LIGHT THE FRYER, MAKE SURE THE GAS CONNECTIONS ARE SECURE AND HAVE BEEN LEAK TESTED AND THE FRYER HAS BEEN PROPERLY FILLED WITH OIL.

(See lighting instructions plate attached to the inner door of Keating Gas Fryer.) Model AA does not require an electrical connection.

Make sure that the Keating Gas Fryer is plugged in. If not your fryer will not operate. Make sure that the main gas valve on the gas supply line to the Keating Gas Fryer is in the "ON" position.

AIR IN THE GAS SUPPLY LINE MAY REQUIRE A LONGER THAN NORMAL PERIOD OF TIME TO LIGHT YOUR FRYER DURING INITIAL INSTALLATION OR AFTER OVERNIGHT SHUTDOWN.

NOTE: Unless you have an AA model your fryer cannot be operated during a power failure.

AA MODELS OPERATING INSTRUCTIONS

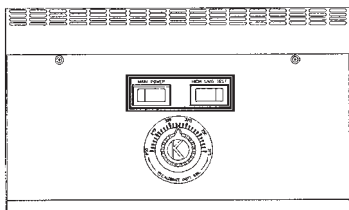

AA CONTROL PANEL - SERIES 2000

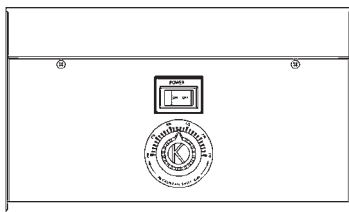

AA CONTROL PANEL - SERIES 2006

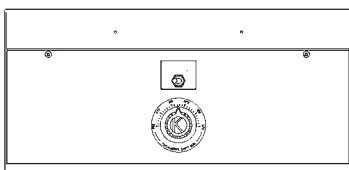

AA CONTROL PANEL - SERIES 2010

⚠ WARNING

DO NOT START FRYER WITHOUT FIRST FILLING FRY POT.

START-UP PROCEDURE

1. Set thermostat to the "OFF" position.
2. Turn "MAIN POWER" switch to the "OFF" position.
3. Turn gas valve knob to "PILOT" position.
4. Light constant pilot located on left side of pilot runner tube.
5. Push and hold the gas valve knob for 30 seconds and release.
6. With the pilot still on, turn gas valve knob to the "ON" position.

7. Set thermostat to desired temperature, turn "MAIN POWER" switch to the "ON" position. The burners will come on.

SHUTDOWN PROCEDURE

1. Set thermostat to the "OFF" position.
2. Turn "MAIN POWER" switch to the "OFF" position.
3. Turn gas valve knob to the "OFF" position.
4. Turn gas supply valve to the "OFF" position.
5. Check to make sure all burners and pilot are extinguished.

SERIES 2000 BB MODELS OPERATING INSTRUCTIONS

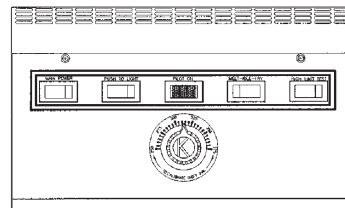

BB CONTROL PANEL - SERIES 2000

⚠ WARNING

DO NOT START FRYER WITHOUT FIRST FILLING FRY POT.

START-UP PROCEDURE

1. Set "MELT-IDLE-FRY" switch to "IDLE" position and thermostat to the "OFF" position.
2. Turn "MAIN POWER" switch to the "ON" position.
3. Light constant pilot located on left side of pilot runner tube.
4. Hold the "PUSH TO LIGHT" switch in until the amber "PILOT ON" light comes on.
5. Set thermostat to desired temperature.
6. Set "MELT-IDLE-FRY" switch to "FRY." The burners will come on. Select "MELT" with solid shortening until liquid shortening is 1" from full, then switch to the "FRY" position after packing shortening around burner tubes.

SHUTDOWN PROCEDURE

1. Set "MELT-IDLE-FRY" switch to "IDLE" position and thermostat to the "OFF" position.
2. Turn "MAIN POWER" switch to the "OFF" position. Its green light will go off.
3. Check to make sure all burners and pilot are extinguished.

**SERIES 2006 BB MODELS
OPERATING INSTRUCTIONS**

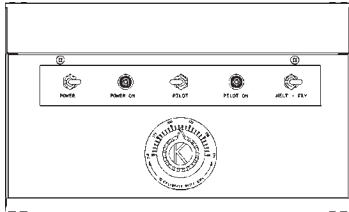

BB CONTROL PANEL – SERIES 2006

⚠ WARNING

DO NOT START FRYER WITHOUT FIRST FILLING FRY POT.

START-UP PROCEDURE

1. Set thermostat to the “OFF” position.
2. Turn “MAIN POWER” switch to the “ON” position. The power ON light will illuminate.
3. Hold the “PUSH TO LIGHT” switch over until the amber “PILOT ON” light comes on. Release switch.
4. Set thermostat to desired temperature.
5. Set “MELT-FRY” switch to “FRY.” The burners will come on. Select “MELT” with solid shortening until liquid shortening is 1" from full, then switch to the “FRY” position after packing shortening around burner tubes.

SHUTDOWN PROCEDURE

1. Set thermostat to the “OFF” position.
2. Turn “MAIN POWER” switch to the “OFF” position.
3. Check to make sure all burners and pilot are extinguished.

**SERIES 2006 BB SPARK IGNITION MODELS
OPERATING INSTRUCTIONS**

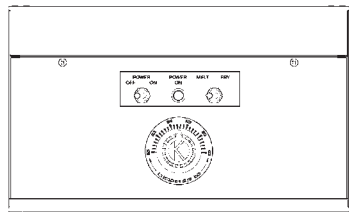

**BB SPARK IGNITION CONTROL PANEL –
SERIES 2006**

⚠ WARNING

DO NOT START FRYER WITHOUT FIRST FILLING FRY POT.

START-UP PROCEDURE

1. Set thermostat to the “OFF” position.
2. Turn “MAIN POWER” switch to the “ON” position. Its light will come on.
3. Set thermostat to desired temperature.
4. Set “MELT-IDLE-FRY” switch to “FRY” with oil in the fry pot. The burners will come on.

5. Set “MELT-FRY” switch to “FRY.” The burners will come on. Select “MELT” with solid shortening until liquid shortening is 1" from full, then switch to the “FRY” position after packing shortening around burner tubes.

SHUTDOWN PROCEDURE

1. Set thermostat to the “OFF” position.
2. Turn “MAIN POWER” switch to the “OFF” position.
3. Check to make sure all burners and pilot are extinguished.

**SERIES 2000 TS MODELS
OPERATING INSTRUCTIONS**

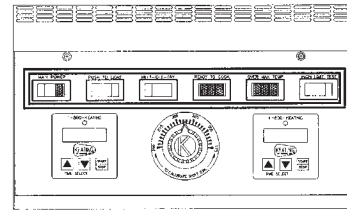

TS CONTROL PANEL – SERIES 2000

⚠ WARNING

DO NOT START FRYER WITHOUT FIRST FILLING FRY POT.

START-UP PROCEDURE

1. Set “MELT-IDLE-FRY” switch to “IDLE” position and thermostat to the “OFF” position.
2. Turn “MAIN POWER” switch to the “ON” position. Its green light and the timers will come on.
3. Light constant pilot located on left side of pilot runner tube.
4. Hold the “PUSH TO LIGHT” switch for 30 seconds. The pilot runner tube will light.
5. Set thermostat to desired temperature.
6. Set “MELT-IDLE-FRY” switch to “FRY” with oil in the pot. The burners will come on. Select “MELT” with solid shortening until liquid shortening is 1" from full mark, then switch to the “FRY” position after packing shortening around burner tubes.

SHUTDOWN PROCEDURE

1. Set “MELT-IDLE-FRY” switch to “IDLE” position and thermostat to the “OFF” position.
2. Turn “MAIN POWER” switch to the “OFF” position. Its green light will go off.
3. Check to make sure all burners and pilot are extinguished.

**SERIES 2006 TS MODELS
OPERATING INSTRUCTIONS**

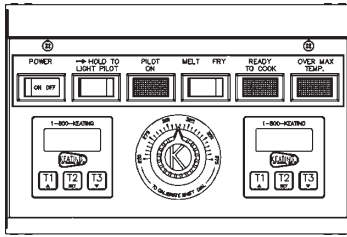

TS CONTROL PANEL – SERIES 2006

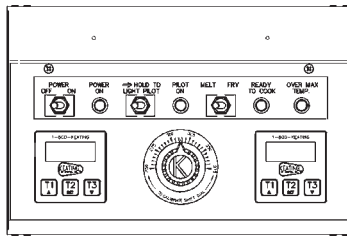

TS CONTROL PANEL – SERIES 2009

**SERIES 2009 TS SPARK IGNITION MODELS
OPERATING INSTRUCTIONS**

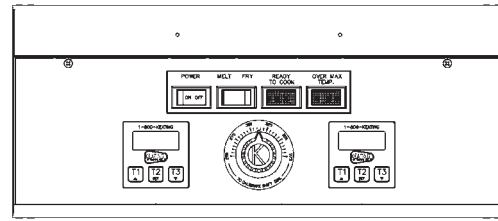

**TS SPARK IGNITION CONTROL PANEL
SERIES 2006**

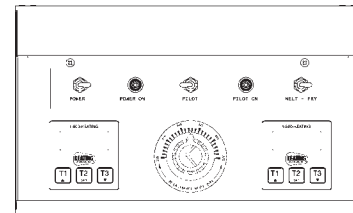

**TS SPARK IGNITION CONTROL PANEL
SERIES 2009**

⚠ WARNING

DO NOT START FRYER WITHOUT FIRST FILLING FRY POT.

START-UP PROCEDURE

1. Set thermostat to the “OFF” position.
2. Turn “MAIN POWER” switch to the “ON” position. Its green light and the timers will come on.
3. Light constant pilot located on left side of pilot runner tube.
4. Hold the “PUSH TO LIGHT” switch for 30 seconds. The pilot runner tube will light.
5. Set thermostat to desired temperature.
6. Set “MELT-IDLE-FRY” switch to “FRY” with oil in the fry pot. The burners will come on. Select “MELT” with solid shortening until liquid shortening is 1" from full mark, then switch to the “FRY” position after packing shortening around burner tubes.

SHUTDOWN PROCEDURE

1. Set thermostat to the “OFF” position.
2. Turn “MAIN POWER” switch to the “OFF” position. Its green light will go off.
3. Check to make sure all burners and pilot are extinguished.

⚠ WARNING

DO NOT START FRYER WITHOUT FIRST FILLING FRY POT.

START-UP PROCEDURE

1. Set thermostat to the “OFF” position.
2. Turn “MAIN POWER” switch to the “ON” position. Its green light and the timers will come on.
3. Set thermostat to desired temperature.
4. Set “MELT-IDLE-FRY” switch to “FRY” with oil in the fry pot. The burners will come on. Select “MELT” with solid shortening until liquid shortening is 1" from full mark, then switch to the “FRY” position after packing shortening around burner tubes.

SHUTDOWN PROCEDURE

1. Set thermostat to the “OFF” position.
2. Turn “MAIN POWER” switch to the “OFF” position. Its green light will go off.
3. Check to make sure all burners and pilot are extinguished.

**SERIES 2000-2010 CPU MODELS
OPERATING INSTRUCTIONS**

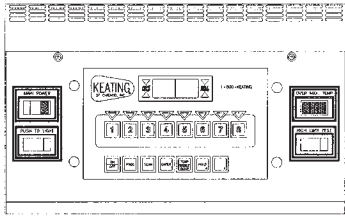

CPU CONTROL PANEL SERIES 2000

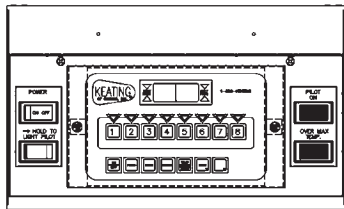

CPU CONTROL PANEL SERIES 2009

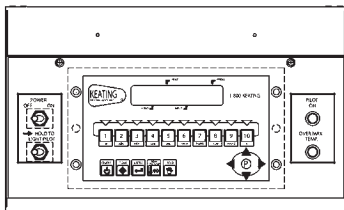

CPU CONTROL PANEL SERIES 2010

⚠ WARNING

DO NOT START FRYER WITHOUT FIRST FILLING FRY POT.

START-UP PROCEDURE

1. Light mini pilot located next to the left burner when facing fryer.
2. Turn gas supply to the "ON" position.
3. Depress the "MAIN POWER" switch to the "ON" position.
4. Make sure CPU is turned off.
5. Engage the (Push to Light) switch and hold until indicator light remains on or the pilot runner tube remains lit.
6. Turn the CPU on by pressing on/off button.
7. Select melt cycle or heat cycle.
8. Select the desired temperature. See the computer manual for more information.

SHUTDOWN PROCEDURE

1. Turn CPU off by pressing the on/off button.
2. Depress the main power switch to the "OFF" position.
3. Turn gas supply to the "OFF" position.
4. Wait five minutes before restarting or relighting fryer

**SERIES 2000 CPU SPARK IGNITION MODELS
OPERATING INSTRUCTIONS**

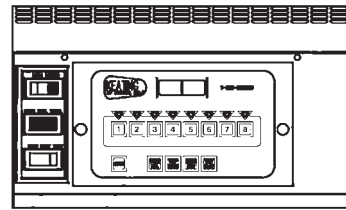

CPU SPARK IGNITION SERIES 2000

⚠ WARNING

DO NOT START FRYER WITHOUT FIRST FILLING FRY POT.

START-UP PROCEDURE

1. Turn gas supply to the "ON" position.
2. Depress the "MAIN POWER" switch to the "ON" position.
3. Turn CPU to the "ON" position.
4. Select melt cycle or heat setting.
5. Select the desired temperature. See the computer manual for more information.

SHUTDOWN PROCEDURE

1. Turn CPU off by pressing the "ON/OFF" button.
2. Depress the main power switch to the "OFF" position.
3. Turn gas supply to the "OFF" position.
4. Wait five minutes before restarting or relighting fryer.

COOKING

Keating Instant Recovery® Gas Fryers are designed to provide maximum production efficiency and deliver high quality food products.

Low-temperature cooking, highly polished stainless steel and a true COLD ZONE mean extended oil life. Follow the cooking procedures for your model.



⚠️ WARNING

- **OPERATION OF THIS FRYER SHOULD BE LIMITED TO PERSONNEL WHO HAVE BEEN THOROUGHLY TRAINED IN OPERATING PROCEDURES.**
- **CARE SHOULD BE TAKEN WHEN LOWERING BASKETS INTO FRYER TO PREVENT SPLASHING HOT OIL FROM FRYER VESSEL.**

If your fryer has timers, push the “T1,” “T2” or “T3” button on the digital timer(s). For fryers with automatic basket lift, basket(s) will lower into fryer vessel.

When timer(s) sounds, carefully lift basket(s) out of hot oil. For fryers with automatic basket lift, a buzzer will sound and the basket(s) will rise automatically. Allow oil to drain before removing.

- **NEVER LIFT BASKETS DIRECTLY OUT OF THE FRYER VESSEL WITHOUT DRAINING, AS SEVERE INJURY MAY RESULT.**
- **USE ONLY KEATING APPROVED BASKETS IN YOUR FRYER. NEVER OVERFILL FRY BASKETS. DO NOT BANG BASKETS ON BASKET HANGERS OR ON FRYER VESSEL.**

Place basket(s) on basket hanger rods on splashback of fryer and allow to drain.

SHUTDOWN INSTRUCTIONS

Always turn the fryer off each night. See Shutdown procedure.

TS MODEL TIMER OPERATING INSTRUCTIONS PART # 056921

DIGITAL TIMERS

The electronic timers, standard on TS models, provide a clearly visible and accurate display and are very easy to use. Three different, independent cook times can be set using this timer - T1, T2, and T3.

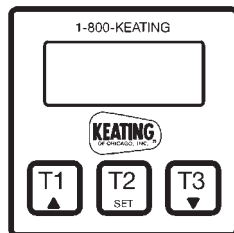

PROGRAMMING

To program the timers, the unit must be in the idle mode. Press and hold the set button for approximately two seconds. The display will show “SEt”. Press T1, T2, or T3 for the cook time to be programmed. The display will show the current setting for that cook time. Use the up or down button to increment or decrement the setting. When the setting is correct, press and hold the set button again for approximately two seconds. The display will show “StO” for approximately two seconds and the timer will return to normal operation. Repeat the process as necessary for the other timers.

OPERATING LOGIC

When the timer is powered up, the display will show the time setting for the cook time that was operated last and the relay output contacts will be open. To start a cycle, press the desired cook time button (T1, T2 or T3). The display will begin to countdown from the preset time setting and the relay output contacts will close. During the countdown the colon will flash at a one-second rate. When the countdown has reached “00:00” the relay output contacts will open, the display will flash, and the audible alarm will sound. To cancel the audible alarm, press any button.

PAUSE FEATURE

To pause a cycle in progress, press any button. The relay output contacts will open, the display will flash, and the countdown will pause. To resume the countdown, press any button. The display will resume the normal countdown and the relay output contacts will close.

CANCELING A CYCLE

To cancel a cycle in progress press and hold any button for approximately two seconds. The relay output contacts will open and the display will show the time setting for the channel last used.

OIL BREAKDOWN

As part of a “Preventive Maintenance Program”, the oil in your fryer needs to be filtered regularly. The initial investment in the frying system is far less than the total overall costs of oil during the life of the fryer, and with regular filtering, you can realize substantial savings in oil costs, as well as maintenance charges. We have listed some of the conditions which are catalysts in the breakdown of oil:

1. Contact with Oxygen
2. Carbonization of Crumbs and Food Particles
3. Non-Stainless Steel Surfaces
4. Keep Salt and Seasonings Away From Oil
5. Prolonged High Temperatures

DRAINING

⚠️ WARNING

ALWAYS SHUT THE FRYER OFF COMPLETELY BEFORE DRAINING. THE FRYER SHOULD BE DRAINED ONLY UNDER THE SUPERVISION OF PROPERLY TRAINED PERSONNEL. A DRAIN PIPE AND COVERED CONTAINER SUITABLE FOR USE WITH HOT OIL SHOULD BE USED TO ENSURE THE SAFETY OF THE OPERATOR.

1. Operator should be outfitted with proper attire including:
 - Oil and heat resistant gloves
 - Oil and heat resistant apron
 - Safety goggles
 - Oil and heat resistant footwear

Figure 2
Operator in Safety Gear

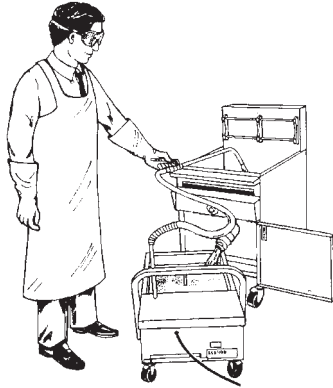

2. Turn off the fryer and open the door.
3. Put suitable container under drain valve.
4. Drain oil from fryer by slowly turning handle. The drain will be completely open after 1/4 turn.
5. After fryer drains, close the drain valve.
6. Filtering may be done at this step.

Note: Fryers with a central filter and under fryer filter will drain differently. (See page 12)

⚠ CAUTION

UNDER NO CIRCUMSTANCES SHOULD YOU PERMIT HOT OIL TO COME IN CONTACT WITH WATER OR ICE. ALL DRAINING SHOULD BE DONE UNDER THE SUPERVISION OF PROPERLY TRAINED PERSONNEL.

A DRAIN PIPE AND COVERED CONTAINER SUITABLE FOR USE WITH HOT OIL SHOULD BE USED WHENEVER A FRYER IS DRAINED. ALWAYS DRAIN OIL INTO A COVERED RECEPTACLE.

CLEANING AND BOIL-OUT

FOR A SINGLE FRYER

When cleaning and boiling out your fryer use Keating Sea Powder and Keating Klenzer to keep your fryer in top condition.

Figure 3
Keating Klenzer and Sea Powder



1. Operator should be outfitted with proper attire including:
 - Oil and heat resistant gloves
 - Oil and heat resistant apron
 - Safety goggles
 - Oil and heat resistant footwear
2. Turn the fryer off. Remove baskets and screen.
3. Drain oil from fryer, see draining.
4. Remove oil container to a secure area to prevent accidental spillage.
5. Close the drain valve.
6. Fill fryer vessel to “Max” line with water.
7. Set thermostat and turn fryer on to bring water to a gentle boil. Once boil has been reached, turn fryer off.

⚠ CAUTION

UNDER NO CIRCUMSTANCES SHOULD THE FRYER BE LEFT UNATTENDED DURING BOIL-OUT. TRAINED PERSONNEL MUST BE PRESENT DURING THE PROCEDURE TO PREVENT BOIL OVER OR TO TURN OFF THE POWER IF WATER DROPS BELOW HEAT TRANSFER TUBES.

8. Dissolve 2/3 cup of Keating Sea Powder for every five gallons of water and let soak for 1/2 hour. If there is a large build-up of carbonized grease, allow for fryer to soak overnight.
9. While soaking, a natural fiber brush may be used to scrub the tubes and inside walls of fryer. Drain the water and Sea Powder into a dry suitable receptacle and remove from cooking area. Sprinkle Keating Klenzer liberally on tubes and sides of fryer vessel. A non-abrasive scouring pad may be used to remove the now softened carbonized grease. Thoroughly rinse fryer vessel with potable water to remove all Klenzer. Prior to refilling with oil, wipe the inside of the fryer vessel making sure all water and Klenzer have been removed.

NOTE: Do not pump water through the filter system.

DO NOT DAMAGE OR REPOSITION THERMOSTAT PROBE AS THIS MAY AFFECT THE ACCURACY OF THE FRYER.

⚠ WARNING

WATER IN ANY FORM AND HOT OIL DON'T MIX!

10. Close the drain.
11. Check thermostat bulb positioning.
12. Refill the fryer with new or filtered oil.

⚠ CAUTION

To avoid damaging the fryer, do not power wash, spray or hose it down while cleaning it.

CLEANING AND BOIL-OUT FOR A FRYER WITH BUILT IN FILTER SYSTEM

When cleaning and boiling out your fryer use Keating Sea Powder and Keating Klenzer to keep your fryer in top condition.

DO NOT PUMP WATER THROUGH YOUR FILTER SYSTEM.

REFER TO YOUR FILTER MANUAL FOR INSTRUCTIONS ON PROPER USE.

SAFE & EASY® FILTER (SIDE VIEW)

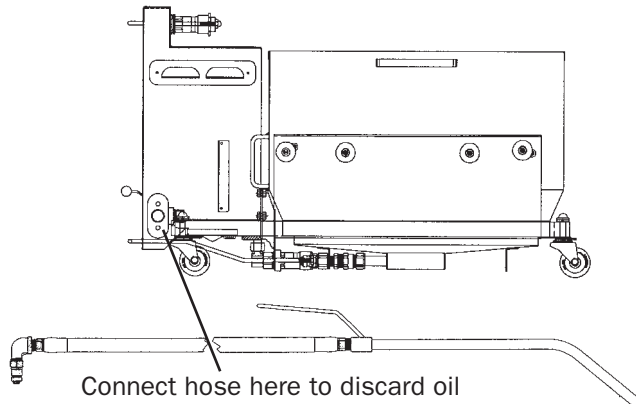

CAUTION

A KEATING FRYER OR FILTER SHOULD BE DRAINED ONLY UNDER THE SUPERVISION OF PROPERLY TRAINED PERSONNEL. WHEN DISCARDING OIL, A COVERED RECEPTACLE APPROVED FOR USE WITH HOT OIL SHOULD BE USED. USE OF A NON-APPROVED RECEPTACLE OR METHOD OF DRAINING THE OIL COULD JEOPARDIZE THE SAFETY OF THE OPERATOR.

WARNING

1. Operator should be outfitted with proper attire including:

- Oil and heat resistant gloves
- Oil and heat resistant apron
- Safety goggles
- Oil and heat resistant footwear

2. Turn the fryer off.

A cleaning hose and wand have been provided for discarding oil.

3. Attach cleaning hose to quick disconnect located on the bottom right side of your filter.

4. Remove baskets and screen. Drain fryer into the central filter drawer.

5. Open the discard valve located near the quick disconnect in the filter cabinet.

6. The hose may now be used to pump the oil into the shortening handling system and discarded properly.

7. Remove oil container to a secure area to prevent accidental spillage.

8. Close the drain valve.

9. Fill fryer vessel to “Fill Level” line with water.

10. Set thermostat and turn fryer on to bring water to a gentle boil. Once boil has been reached, turn fryer off.

CAUTION

UNDER NO CIRCUMSTANCES SHOULD THE FRYER AND FILTER BE LEFT UNATTENDED DURING BOIL-OUT. TRAINED PERSONNEL MUST BE PRESENT DURING THE PROCEDURE TO PREVENT BOIL OVER OR TO TURN OFF THE POWER IF WATER DROPS BELOW HEATING TRANSFER TUBES.

11. Dissolve 2/3 cup of Keating Sea Powder for every five gallons of water and let soak for 1/2 hour. If there is a large build-up of carbonized grease, allow fryer to soak overnight.

12. While soaking, a natural fiber brush may be used to scrub the tubes and inside walls of fryer. Pump the water and Sea Powder into a dry suitable receptacle and remove from cooking area. Sprinkle Keating Klenzer liberally on tubes and sides of fryer vessel. A non-abrasive scouring pad may be used to remove the now softened carbonized grease. Thoroughly rinse fryer vessel with potable water to remove all Klenzer. Prior to refilling with oil, wipe the inside of the fryer vessel making sure all water and Klenzer have been removed.

DO NOT DAMAGE OR REPOSITION THERMOSTAT PROBE AS THIS MAY AFFECT THE ACCURACY OF THE FRYER.

WARNING

WATER IN ANY FORM AND HOT OIL DON'T MIX!

13. Close the drain valve and disconnect the cleaning hose from filter machine.

Quick disconnect will remain hot for approximately 15 minutes.

14. Check thermostat bulb positioning (should be 1 paper thickness away from heat tube).

15. Refill the fryer with new or filtered oil. Wait until filter drawer is cool before cleaning, approximately 15 minutes.

16. Remove filter drawer, drain, clean and dry.

17. Prepare filter drawer and return to filter cabinet.

⚠ CAUTION

To avoid damaging the fryer, do not power wash, spray or hose it down while cleaning it.

18. Pump must be primed with oil after boil-out with water.

FAILURE TO LUBRICATE PUMP MAY CAUSE SEVERE DAMAGE TO FILTER SYSTEM.

SELF HELP GUIDE

Before calling for service, review this list. It may save you both time and expense. This list includes common occurrences that are not the result of defective workmanship or materials in this appliance.

PROBLEM	SOLUTION
Fryer does not operate	<ul style="list-style-type: none"> • Check power cord, unit plugged in? • Thermostat is in the OFF position. • Check gas supply. • Reset high limit.

NOTE: For a fryer with a Central or Safe & Easy® Filter always check the rear drain operating handle before attempting to use the fryer. A safety switch prevents the fryer from operating if the handle is not pushed in completely and latched. (See figure 4)

Figure 4

Rear Drain Operating Handle

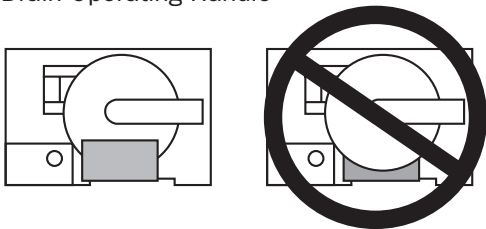

PREVENTIVE MAINTENANCE

Preventive maintenance should be done in daily, weekly, monthly and yearly intervals as necessary. Following preventive maintenance procedures will help keep your fryer working efficiently. Proper care and servicing will lead to years of quality performance.

PREVENTATIVE MAINTENANCE CHART

TIME FRAME	OPERATOR/OWNER
AT LEAST DAILY*	<ul style="list-style-type: none"> • Check lights and controls. • Check that the oil is up to "Max" line. • Clean all baskets. • Drain, strain or filter oil.
AT LEAST WEEKLY*	<ul style="list-style-type: none"> • Drain and clean fryer. • Boil-out fryer.
AT LEAST BI-MONTHLY*	<ul style="list-style-type: none"> • Hi-Limit & Test procedures.
AT LEAST MONTHLY*	<ul style="list-style-type: none"> • Check calibration of Thermostat.
TIME FRAME	QUALIFIED SERVICE PERSONNEL
AT LEAST YEARLY*	<ul style="list-style-type: none"> • Check burner flame color and adjust air shutters. • Disassemble fryer to clean pilot and burner orifices and runner pilot tube. • Clean Pilot Runner Tube. • Check and replace wing turbulators.

*High production facilities should be checked more often. Contact the factory or a local service company to perform maintenance and repairs.

HI-LIMIT CHECK BI-MONTHLY

Place an accurate thermometer in the oil. If the Hi-Limit Control doesn't shut off the fryer between 425°F and 450°F, have it replaced.

LIMITED CALIBRATION

(Less than 25° difference)

You will need:

- One screwdriver with 1/8" wide flat blade
- One accurate fryer thermometer

Figure 5

Thermostat knob removed to reveal calibration screws

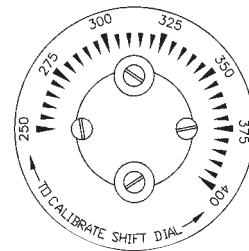

1. Set thermostat to desired frying temperature.
2. Allow fryer to cycle three times.
3. Place an accurate thermometer in the oil.

NOTE: Locate thermometer in same position for every calibration. Left front corner of fryer vessel at the High Limit Bulb is recommended.

4. If temperature of fryer is found to be more or less than 25°F off, remove the thermostat knob. There are (4) screws holding the dial plate in place. Loosen the screws and reset the dial plate to match the thermometer reading.

⚠ WARNING

DO NOT ADJUST THE THERMOSTAT SET SCREW - IT VOIDS ANY WARRANTY ON PART.

THERMOSTAT BULB POSITIONING

BEFORE REPLACING, TEST THERMOSTATS

NOTE: Operational problems can easily be corrected by thermostat bulb positioning.

Keating's patented thermostat application is accurate within 2°F of the dial setting between 250°F – 350°F. This accuracy is attained only if the thermostat bulb is placed properly against the heat transfer tube. To quickly and accurately test for proper bulb placement, a single thickness of writing paper should be pulled through between the tube and the bulb with medium resistance.*

Thermostat Bulb Positioning 10x11, 18 & Up

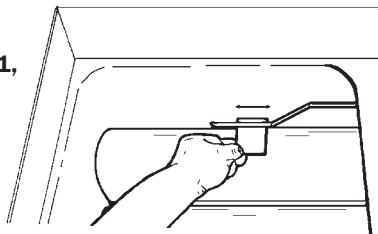

1. *For 14" Gas Fryers:

- The end of thermostat bulb should touch the burner tube.

2. For 10x11", 18" & Up Gas Fryers:

- If the bulb is too loose, the paper will slip through with little or no resistance. A fryer with a thermostat bulb that is too loose will overshoot.

Overshoot: The thermostat takes a long time to cycle and then misses its preset temperature by 20°F - 40°F yielding a poor quality product.

- If the bulb is too tight, the paper will either not pull through or it will tear. A fryer with a thermostat bulb that is too tight will short cycle.

Short Cycle: The thermostat will cycle rapidly while the fryer is in the idle mode; the temperature will be erratic.

REQUIRED TEST THERMOSTAT Multimeter (for testing continuity)

CHECKING CONTINUITY WITH THE MULTIMETER

1. Rotate the thermostat shaft until an audible click is heard.
2. Rotate the thermostat shaft left and right ten times causing the switch to click on and off ten times, while using the Multimeter to verify continuity.
3. If the switch does not show continuity during all ten trials, replace the thermostat.

⚠ WARNING

DISASSEMBLING THE THERMOSTAT WILL VOID THE THERMOSTAT WARRANTY.

1. Set compression ring onto capillary end of bulb finger tight, 1/2" from end of capillary.
2. Insert new thermostat bulb through control panel back.
3. Apply oil resistant flexible sealant onto compression fitting thread before installing fitting into fryer vessel.
4. Position bent portion of bulb against far right heat transfer tube and install compression fitting snugly into fryer vessel.
5. Adjust bulb so at least 2" of bent portion of it is next to heat transfer tube and tighten compression nut onto compression fitting for fryer 10x11, 18 & up. The end of thermostat bulb should touch the burner tube for 14" fryers.
6. Replace burners.
7. Replace control panel back.
8. Slide back fabric shield over capillary and carefully coil capillary. Avoid crimping.
9. Reconnect wires to thermostat body.
10. Replace two screws which hold thermostat body to control panel.
11. Replace control panel.
12. Replace three retaining screws and washers which hold dial plate in place.
13. Replace thermostat knob.
14. Connect electric power source. Turn on gas and pilots.
15. Boil out fryer.
16. Refill fryer with oil to "fill level line".
17. Start fryer, preheat and calibrate with thermometer.

**MILLIVOLT GAS VALVES Part # 023625 (Natural)
& 023624 (LP)**

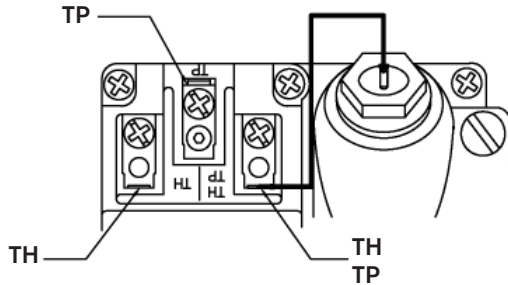

MILLIVOLT CONTROL VALVE

To check Resistance of the gas valve, connect one wire to the valve as shown.

1. Resistance between the THTP & TH terminals must be $11.5\Omega \pm 0.2\Omega$
2. Resistance between the THTP & TP terminals must be $10.0\Omega \pm 0.2\Omega$

If resistance is outside of specifications listed, the gas valve must be replaced.

**BEFORE REPLACING THERMOPILE CHECK
MILLIVOLT READINGS**

THERMOPILE READINGS

With all wires connected, with the pilot on and burners off, the thermopile reading at the TP&THTP terminals should be ~325mv. With the burners on, the millivolt reading should be ~200mv. A replacement thermopile part # is 022770.

WARRANTY REPAIRS

Keating's warranty begins with the date of installation. In the event that your Instant Recovery® Fryer, under warranty, needs repairs other than routine cleaning, you are requested to contact KEATING OF CHICAGO, INC. (1-800 KEATING).

■ SERVICE DIAGNOSIS

The following diagnosis is only to be used as a guide to qualified service personnel. Keating recommends that you use a qualified & licensed service company. (Equipment still under warranty requires it.) Call 1-800-KEATING if you need assistance in locating a qualified service company.

NOTE: To correctly and quickly diagnose the system, the chart below should be followed in sequential order.

TROUBLE SHOOTING CHART

PROBLEM	PROBABLE CAUSE	SOLUTION
Constant pilot won't light	<ul style="list-style-type: none"> a. Gas isn't turned on. b. Clogged constant pilot tubing. c. Constant pilot valve isn't turned on. 	<ul style="list-style-type: none"> a. Turn manual gas valve on. If using flexible connector with quick disconnect, make sure quick disconnect is completely engaged. b. Turn fryer and manual gas valve off. Clean tubing. c. Turn constant pilot valve on and adjust pilot flame height to 3/8" to 1/2" flame.
Runner pilot tube won't light	<ul style="list-style-type: none"> a. Gas isn't turned on. b. No electricity to fryer (BB & TS models). c. Gas valve knob in incorrect position (AA & CMG models) d. Hi-Limit has been activated. e. Clogged runner pilot orifice(s). f. Drain valve isn't pushed in completely (fryers with built-in filter system). 	<ul style="list-style-type: none"> a. Turn manual gas valve on. If using flexible connector with quick disconnect, make sure quick disconnect is completely engaged. b. Plug fryer into approved outlet. c. Rotate gas valve knob to pilot position. Depress and hold for 30 seconds. d. Push Hi-Limit reset button located under control panel. e. Turn fryer and manual gas valve off. Clean orifice(s) and other parts as necessary. f. Push in and latch drain valve handle to activate rear drain safety switch. Turn off fryer & turn back on.
Runner pilot won't stay lit	<ul style="list-style-type: none"> a. Low gas supply or pressure. b. Dirty runner pilot tube or pilot orifice(s). c. Low pilot flame height. d. Flame switch control is faulty (BB & TS models). e. Hi-Limit has been activated. f. Exhaust problems or drafts in kitchen. g. Thermopile or gas valve is faulty (AA & CMG models). h. Delayed ignition. 	<ul style="list-style-type: none"> a. Verify if size of incoming gas line to fryer and manifold gas pressure are adequate. b. Turn fryer and manual gas valve off. Clean orifice(s) and pilot tube. c. Adjust pilot flame height. d. If it takes more than 60 seconds for pilot to stay lit, replace flame switch control. e. Push Hi-Limit reset button located under control panel. f. Install or adjust flue restrictors. If problem persists, contact your HVAC representative. g. Perform millivolt tests. Replace faulty thermopile or gas valve. h. See diagnosis on page 17.

PROBLEM	PROBABLE CAUSE	SOLUTION
Burners with not light	<ul style="list-style-type: none"> a. Gas valve knob in incorrect position. (AA & CMG Models) b. Switch not set to fry. (BB and TS Models) c. Thermostat is faulty. d. Fry/Off/Melt switch (BB & TS models) or On/Off switch (AA & CMG models) is faulty. e. Faulty gas valve. 	<ul style="list-style-type: none"> a. Rotate gas valve knob to ON. Turn power switch ON. Set thermostat to desired temperature. b. Set MELT/IDLE/FRY switch (or MELT/FRY switch) to FRY. Set thermostat to desired temperature. c. Push and hold in Hi-Limit test button. If burners come on, replace thermostat. d. Replace switch. e. Replace gas valve.
Fryer overshoots temperature setting	<ul style="list-style-type: none"> a. Thermostat bulb improperly placed. b. Thermostat out of calibration. 	<ul style="list-style-type: none"> a. Adjust bulb position. See page 14, Thermostat Bulb Positioning. b. Calibrate thermostat. See page 13, Calibration.
Delayed ignition	<ul style="list-style-type: none"> a. Dirty runner pilot tube or pilot orifice(s). b. Low pilot flame height. c. Exhaust problems or drafts in kitchen. d. Low gas supply or pressure. 	<ul style="list-style-type: none"> a. Turn fryer and manual gas valve off. Clean orifice(s) and pilot tube. b. Adjust pilot flame height. c. Install or adjust flue restrictors. If problem persists, contact your HVAC representative. d. Verify if size of incoming gas line to fryer and manifold gas pressure are adequate.
Oil in fryer vessel smokes	<ul style="list-style-type: none"> a. Oil has begin to breakdown. b. High carbon content in oil. c. Dirty fryer vessel. d. Inferior grade of oil. e. Fryer is overheating. f. Hi-Limit Control has failed. 	<ul style="list-style-type: none"> a. Replace oil. b. Filter oil completely, replace if necessary. c. Boil-out fryer. d. Check with supplier for the grade of oil needed for your cooking applications. e. Check calibration of thermostat (See page 13) and replace if necessary. f. Check if Hi-Limit trips at 425° F. If not, replace Hi-Limit.
Fryer vessel boiling over	<ul style="list-style-type: none"> a. Over-filling fryer with oil. b. Product overloaded in fryer vessel. c. Oil breakdown causing foaming. d. Water in the cold zone. 	<ul style="list-style-type: none"> a. Fill fryer up to "Max Level" line as oil will expand when heated. b. Follow recommended cooking production figures in determining proper size of loads c. Replace oil. d. Stir oil repeatedly with a paddle until water boils off. Filter oil. If necessary, allow oil to cool. Drain about one quart of it to remove remaining water.
Flames come out top of flue	<ul style="list-style-type: none"> a. Excessive gas supply or pressure. b. Collapsed burner radiants. c. Exhaust problems. 	<ul style="list-style-type: none"> a. Adjust pressure, change burner orifices or install in-line regulator. b. Replace radiants. c. Install or adjust flue restrictors. If problem persists, contact your HVAC representative.

PROBLEM	PROBABLE CAUSE	SOLUTION
Flames come out front of fryer	<ul style="list-style-type: none"> a. Exhaust problems. b. Radiants have slipped forward. c. Flue blockage. 	<ul style="list-style-type: none"> a. Install deflector to block down draft. Install or adjust flue restrictors. If problem persists, contact your HVAC representative. b. Reposition radiants. c. Turn fryer and manual gas valve off. Let flue cool and remove foreign objects.
Fryer has poor recovery or runs cold	<ul style="list-style-type: none"> a. Baskets overfilled. b. Fryer vessel overfilled with oil. c. Carbon coating on heat transfer tubes. d. Radiant collapsed or out of position. e. Faulty or erratic thermostat. f. Low gas supply or pressure. g. Thermostat bulb improperly placed. 	<ul style="list-style-type: none"> a. Don't over fill baskets. b. Fill fryer up to "Fill Level" line or "Max Level" line as oil expands when heated. c. Boil-out fryer. See pages 11-13, Cleaning and boil-out. d. Reposition or replace radiants. e. Replace thermostat. f. Verify if size of incoming gas line to fryer and manifold gas pressure are adequate. g. Adjust bulb position. See page 13, thermostat bulb positioning.
Basket-Lift mechanism will not operate	<ul style="list-style-type: none"> a. Connections are loose or timer faulty. b. Breaker has tripped. c. Basket-lift relay is faulty. d. Actuator is defective. 	<ul style="list-style-type: none"> a. Tighten connections. Replace timer if faulty. b. Reset breaker located on power box in rear of fryer. Circuit breakers on newer units can be found under the control panel. c. Replace relay. d. Replace actuator if 24VDC is present.
Fryer is making a lot of noise	<ul style="list-style-type: none"> a. Misadjusted air shutters on the burners. 	<ul style="list-style-type: none"> a. Loosen screw that holds the air shutter on the burner. Move air shutter so the screw is in the middle of the slot on the shutter. Make all the shutters the same.

■ ORDERING PARTS

Parts may be ordered by calling 1-800-KEATING or your local Keating service company. We recommend using genuine Keating Replacement Parts - engineered and manufactured specifically to meet exact specifications and requirements for Keating equipment.

Refer to the Keating Gas Fryer Limited Warranty for complete service and ordering information.

The model/serial plate is attached to the inside of the front door. The serial and model numbers are necessary when ordering.

NOTE: On Drop-In fryers, the model/serial plate is attached to the top of the control panel.

WARNING AND OPERATING PLATES

All warning and operating plates on the Instant Recovery® Gas Fryer should be in place at all times. If plates are damaged or lost, replace them immediately.

GAS FRYER PARTS LIST - MODELS WITH UNI-POT

(Part numbers correspond to pages 20-22)

ITEM	DESCRIPTION	MODEL	PART #	10x11	14	Quantity Per Model				
						18	20	24	34x24	
1	GAS VALVE, MILLIVOLT	AA, CMG								
		NATURAL	023625	1	1	1	1			
		PROPANE	023624	1	1	1	1			
	GAS VALVE, 24V	BB, TS								
	1/2" x 1/2" - Series 2003 - 2005			1	1	1	1	1		
	with Red Slide Switch	NATURAL	024030	1	1	1	1	1		
	with Red Slide Switch	LP	024988	1	1	1	1	1		
	1/2"	NATURAL	021675	1	1	1	1	1		
		LP	021676	1	1	1	1	1		
	3/4" x 3/4" - Series 2008	NATURAL	054324							1
		LP	054324							1
	TAN KNOB	AA, CMG	004803	1	1	1	1			
	PILOT OPERATING HANDLE	CMG	019426	1	1					
	BRACKET FOR PILOT	CMG	004804	1	1					
	OPERATING HANDLE W/SCREW									
	SCREW FOR KNOB	AA, CMG	004805	1	1	1	1			
2	THERMOPILE	AA, CMG	022770	1	1	1	1			
3	RUNNER PILOT TUBE	1-800-KEATING		1	1	1	1	1	1	
4	CONSTANT PILOT ASSEMBLY	ALL	004259	1	1	1	1	1	1	
5	CONSTANT PILOT VALVE	ALL	004266	1	1	1	1	1	1	
6	RUNNER PILOT AIR SHUTTER	NIPPLE W/NUT	015747	1	1	2	2	2	2	3
		CLIP	004090	1	1	2	2	2	2	3
7	RUNNER PILOT ORIFICE	1-800-KEATING		1	1	2	2	2	2	3
8	RUNNER PILOT ORIFICE HOLDER	STRAIGHT	004142	1	1	2	2	2	2	3
9	CENTER PILOT ORIFICE HOLDER		017385							1
10	RUNNER PILOT 90° ELBOW	(1/4" - 1/8")	038566	1	1	2	2	2	2	2
11	RUNNER PILOT TEE	IN TUBING	006474			1	1	1	1	2
12	RUNNER PILOT SOLENOID ADAPTER	ALL	005743	1	1	1	1	1	1	1
13	ALUMINUM 1/4" TUBING (Specify length)									
	SERIES 2000 - 2005	1-800-KEATING		1	1	3	3	3	3	5
14	CORRUGATED 1/4" TUBING (Specify length)	1-800-KEATING								
15	RADIANT, TURBULATOR	ALL	056125	2	3	4	4			6
16	BURNER	ALL	028048	2	3	4	4	5	5	6
17	BURNER ORIFICE	1-800-KEATING		2	3	4	4	5	5	6
18	BURNER HOLD DOWN BAR	1-800-KEATING		1	1	1	1	1	1	2
19	BURNER SPACER	18 AND ABOVE	019683			4	4	5	5	6
20	FRYER VESSEL	1-800-KEATING		1	1	1	1	1	1	1
21	DRAIN VALVE, FRONT, 1"	AA, BB, TS, CMG	004553	1	1					
	DRAIN VALVE, REAR, 1"	AA, BB, TS	016341	1	1					
	DRAIN VALVE, FRONT, 1 1/4"	AA, BB, TS	004554	1	1	1	1	1	1	1
	DRAIN VALVE, REAR, 1 1/4"	AA, BB, TS	016342			1	1	1	1	2
	DRAIN VALVE, FRONT, 2"	AA, BB, TS	021256				1	1		
	DRAIN VALVE, FRONT, 2"	AA, BB, TS	019722			1				
22	DOOR CATCH, MAGNET	AA, BB, TS, CMG		1	1	1	1	1	1	2
	SERIES 2000 -11/2001	AA, BB, TS, CMG	030851							
	SERIES 2001 - CURRENT	AA, BB, TS, CMG	053386							
23	HI-LIMIT CONTROL W/RESET	AA, BB, TS, CMG				SEE PAGES 21-22				
24	THERMOSTAT	SEE MODEL				SEE PAGES 21-22				
25	BASKET HANGER	AA, BB, TS, CMG				SEE BELOW				
26	MAIN SUPPLY GAS VALVE	BB, TS, CMG	019515	1	1	1	1	1	1	1
		18-20 AA	004542							
		10x11, 14 AA	019514	1	1					
27	DOOR HANDLE	ALL	004542							

ITEM	DESCRIPTION	MODEL	10x11	14	18	20	24
25	BASKET HANGER		018553	018477	018556	018559	018562
	BOLT 1/4 - 20 x 1/2 SHOULDER WITH FLATS		016782				

GAS FRYER ASSEMBLY

(See Part Numbers on page 19)

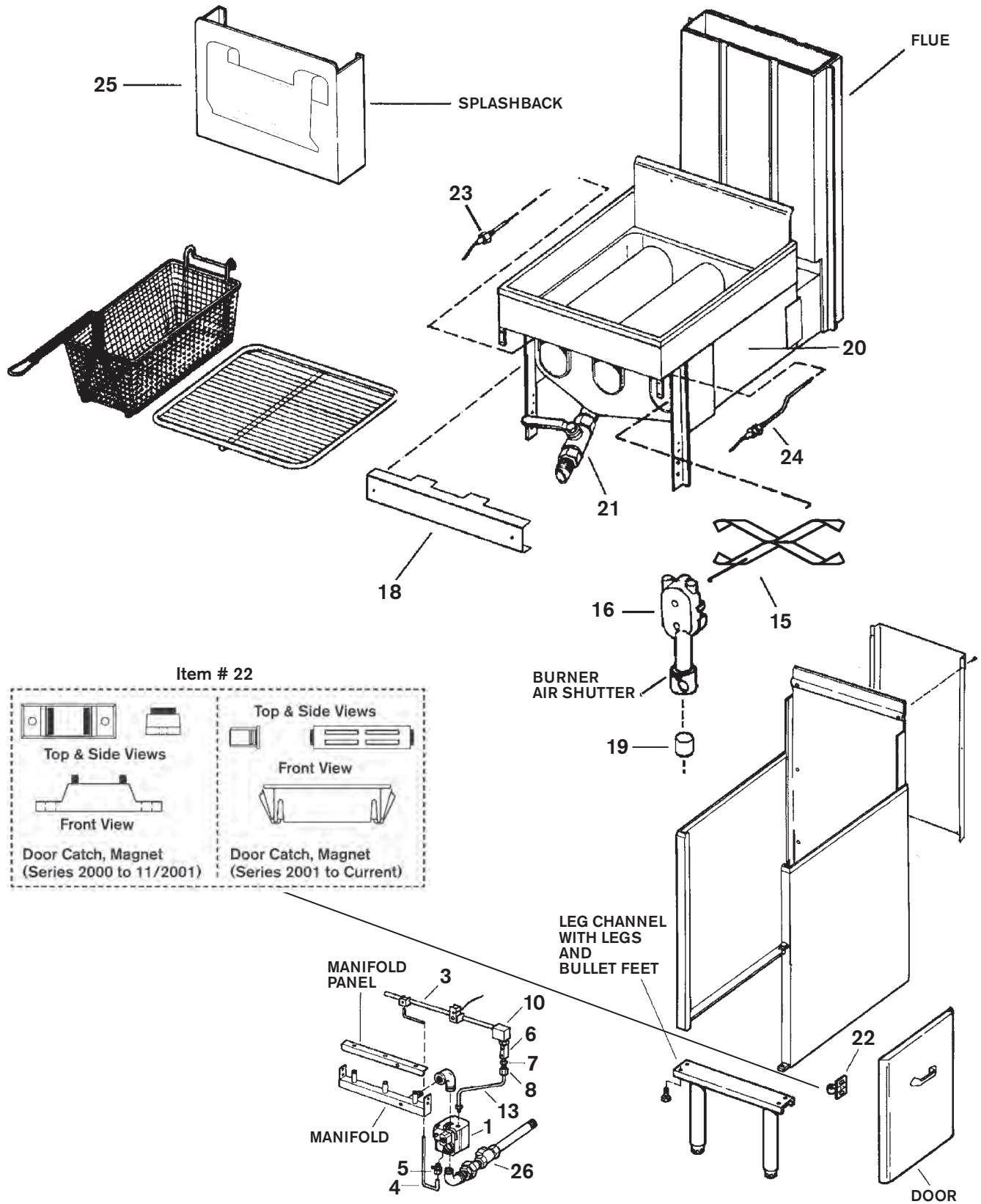

RUNNER PILOT ASSEMBLY - SERIES 2000 - 2005

(Spark Ignition Models see page 30)

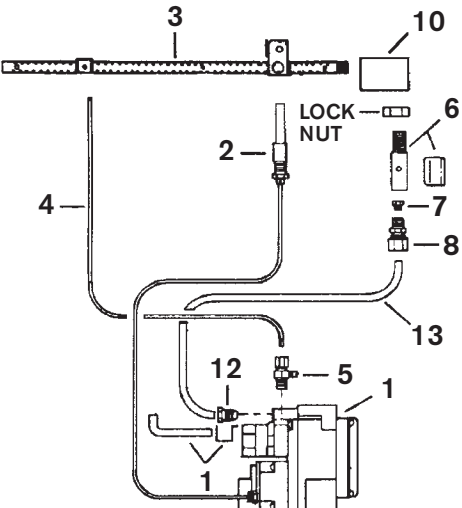

Models 10x11, 14 AA, CMG

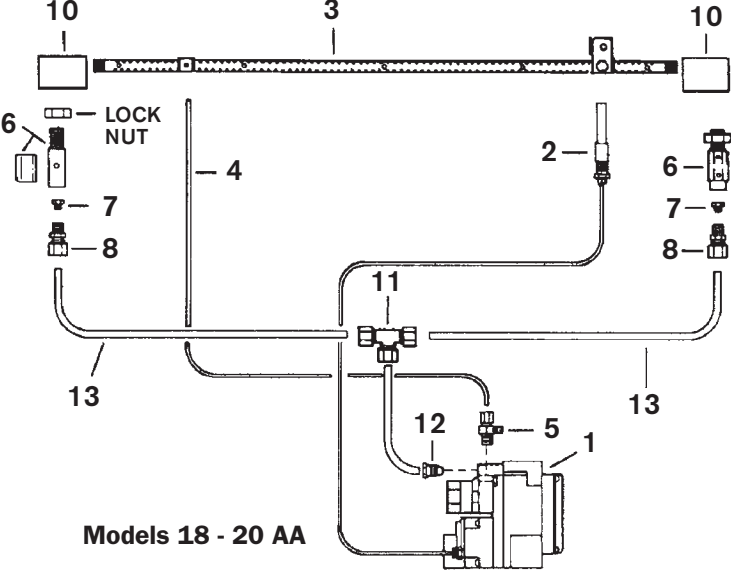

Models 18 - 20 AA

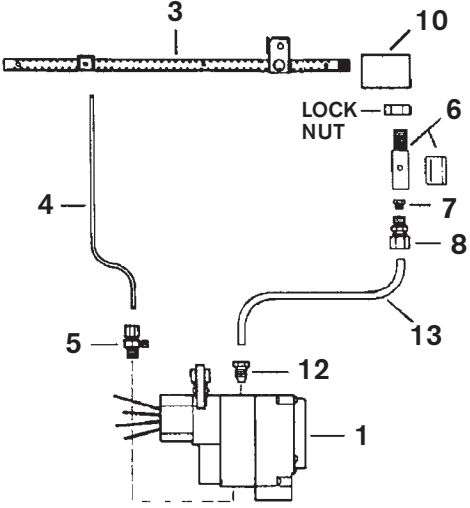

Models 10x11, 14 BB, TS

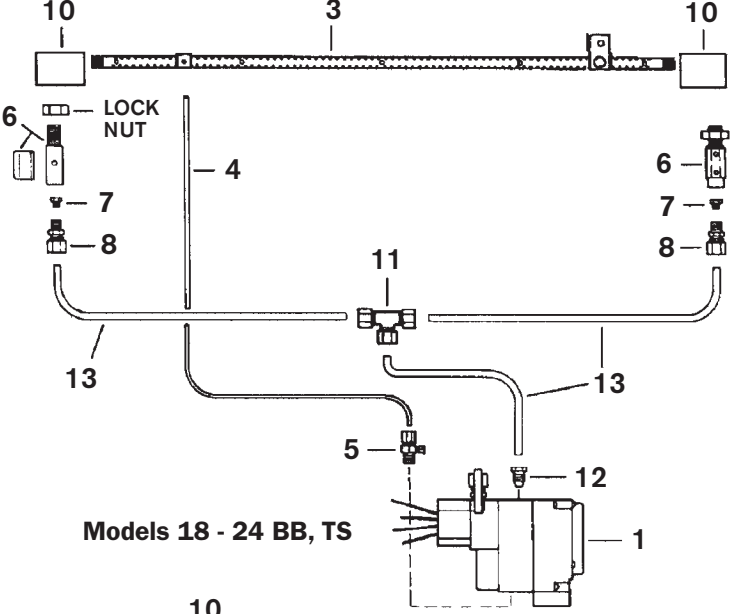

Models 18 - 24 BB, TS

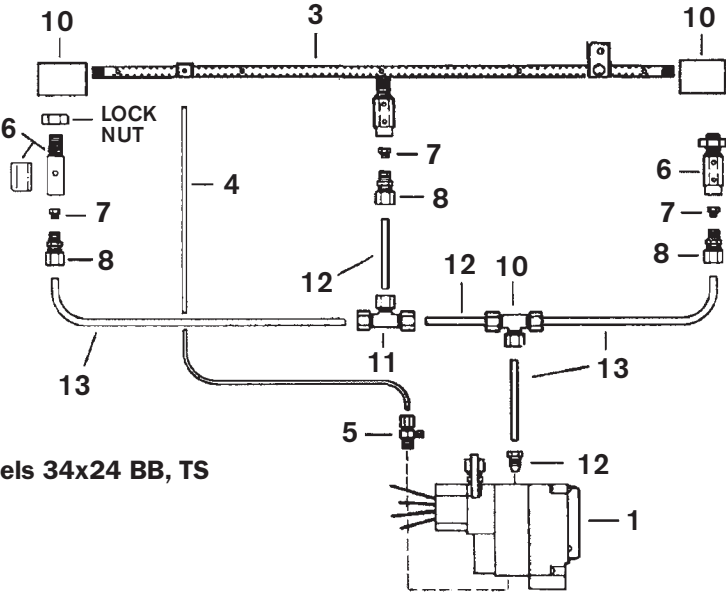

Models 34x24 BB, TS

RUNNER PILOT ASSEMBLY - SERIES 2005 - 2009

(Spark Ignition Models see page 30)

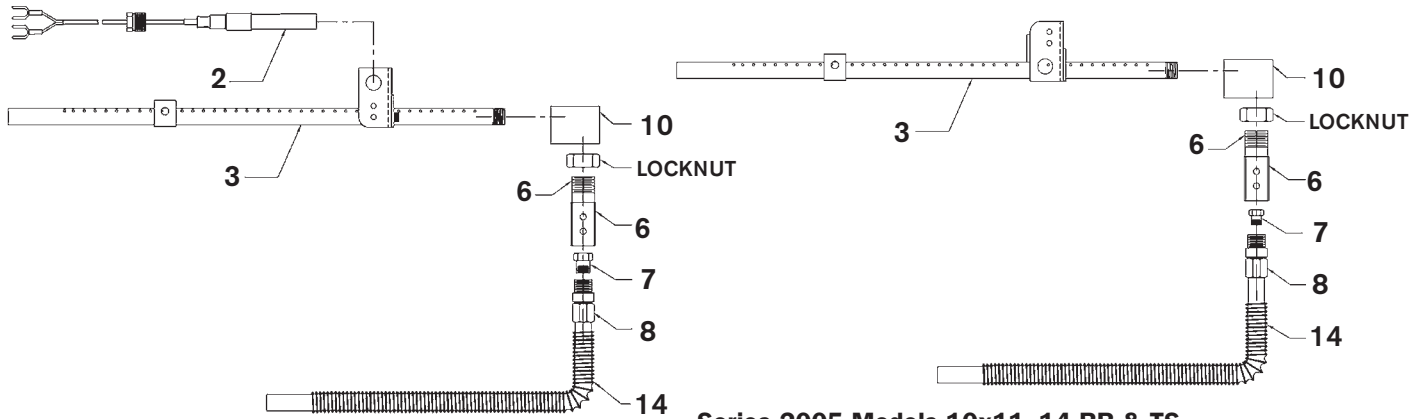

Series 2005 Models 10x11, 14 AA & CMG

Series 2005 Models 10x11, 14 BB & TS

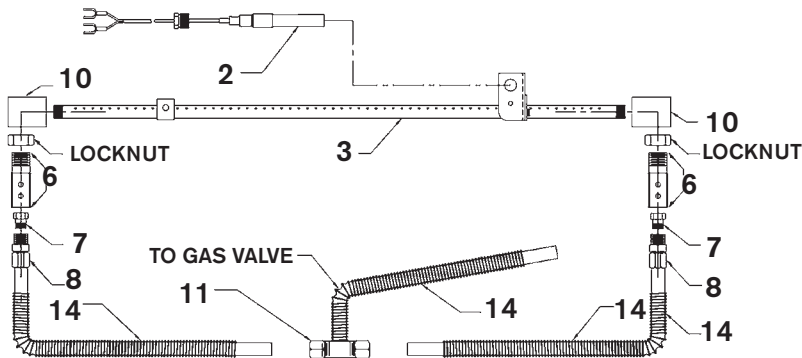

Series 2005 Models 18 & 20 AA

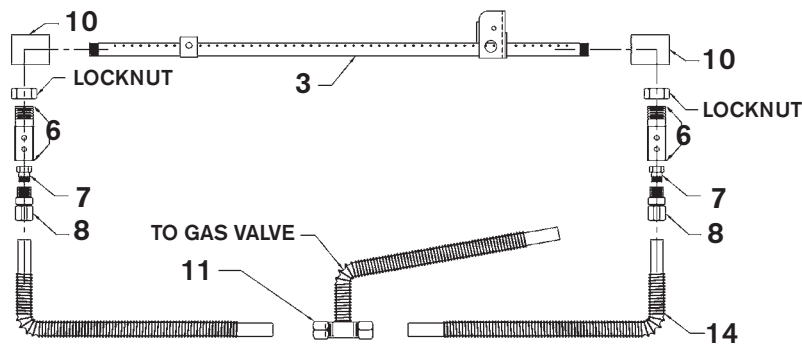

Series 2005 Models 18 & 24 BB & TS

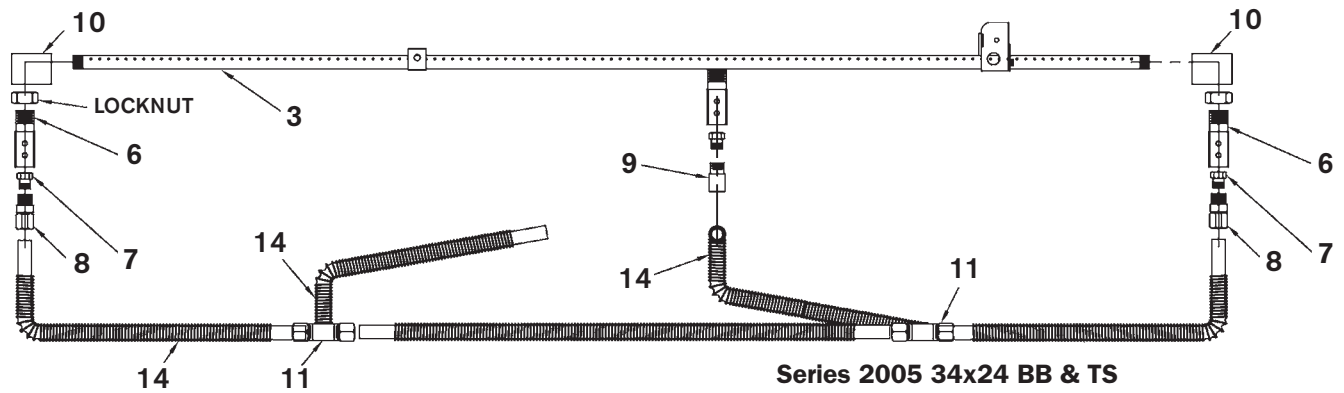

Series 2005 34x24 BB & TS

CONTROL PANEL AA & CM GAS - SERIES 2000

CONTROL PANEL FRONT

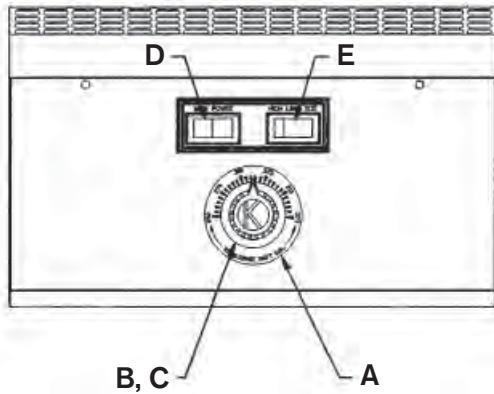

BACK PANEL

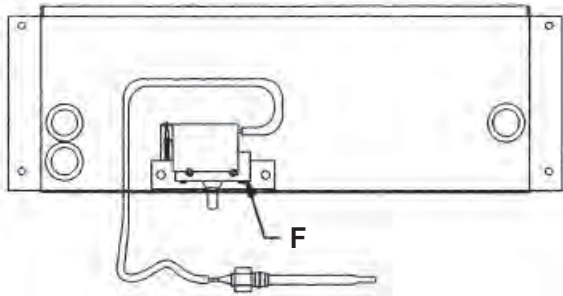

ITEM	QTY	DESCRIPTION	P/N
A	1	THERMOSTAT DIAL PLATE 250°- 375°F	058037
B	1	THERMOSTAT KNOB, BLACK	060612
C	1	GAS FRYER THERMOSTAT 14AA ,14CM 10x11AA, 18AA and Larger	023145 035553
D	1	SWITCH ROCKER WHITE ON/OFF	035030
E	1	HIGH LIMIT TEST SWITCH	032297
F	1	HIGH LIMIT (Resettable) *BOTTOM MOUNT *BACK MOUNT	1-800-KEATING 034357 004341

*LOCATED ON REAR DRAIN UNITS ONLY

CONTROL PANEL AA & CM GAS - SERIES 2006

CONTROL PANEL FRONT

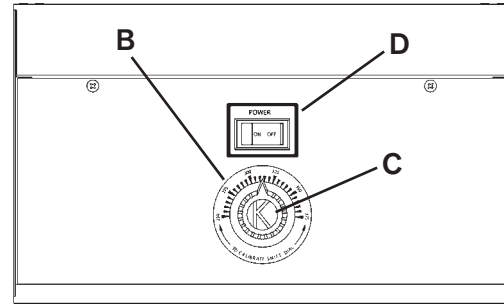

BACK PANEL - REAR DRAIN UNIT (Not CM)

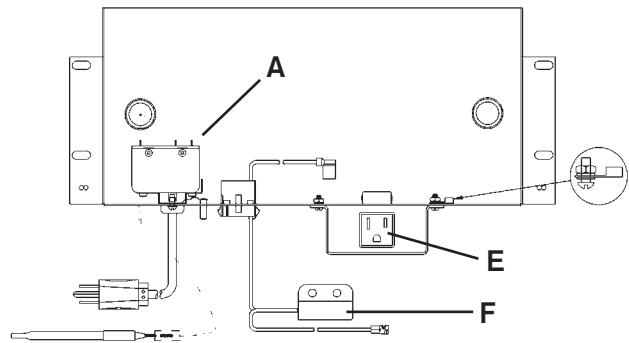

ITEM	QTY	DESCRIPTION	P/N
A	1	HIGH LIMIT (Resettable) *BOTTOM MOUNT *BACK MOUNT	1-800-KEATING 034357 004341
B	1	THERMOSTAT DIAL PLATE 250°- 375°F	058037
C	1	THERMOSTAT KNOB, BLACK GAS FRYER THERMOSTAT 14AA, 14CM 10x11AA, 18AA and Larger	060612 023145 035553
D	1	SWITCH ROCKER WHITE ON/OFF	035030
E*	1	RECEPTACLE, 120V	011505
F*	1	MAGNETIC SAFETY SWITCH	058683

*LOCATED ON REAR DRAIN UNITS ONLY

CONTROL PANEL AA & CM GAS - SERIES 2010

CONTROL PANEL FRONT

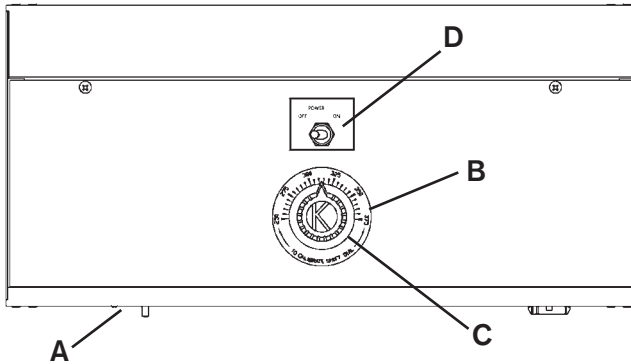

BACK PANEL - FRONT DRAIN UNIT

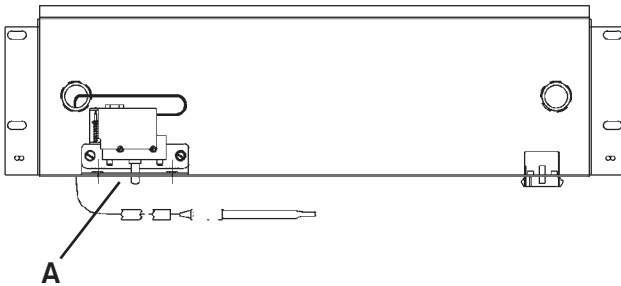

ITEM	QTY	DESCRIPTION	P/N
A	1	HIGH LIMIT (Resettable) *BACK MOUNT	004341
B	1	THERMOSTAT DIAL PLATE 250°-375°F	058037
C	1	THERMOSTAT KNOB, BLACK	060612
	1	GAS FRYER THERMOSTAT 14AA, 14CM	023145
		10x11AA, 18AA and Larger	035553
D	1	SWITCH TOGGLE POWER	059141
E*	1	RECEPTACLE, 120V	011505
F*	1	MAGNETIC SAFETY SWITCH	058683

*LOCATED ON REAR DRAIN UNITS ONLY

CONTROL PANEL BB GAS - SERIES 2000

CONTROL PANEL FRONT

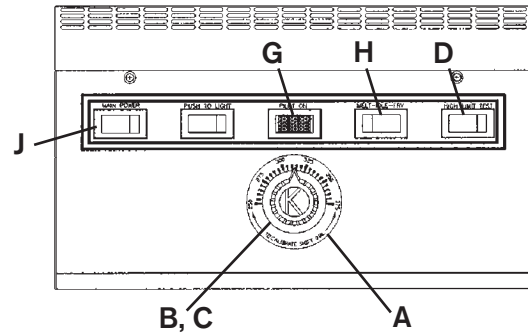

BACK PANEL

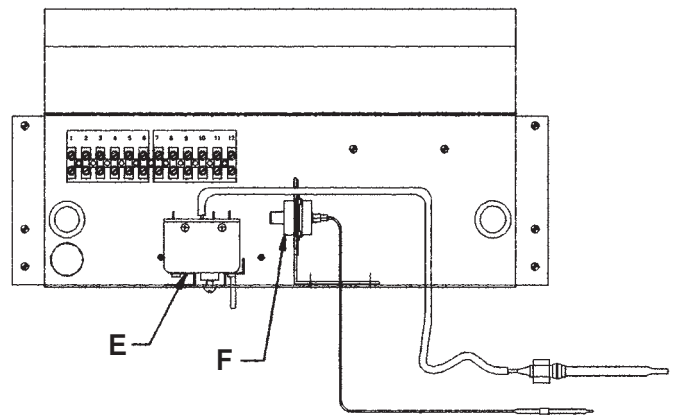

ITEM	QTY	DESCRIPTION	P/N
A	1	THERMOSTAT DIAL PLATE 250°-375°F	058037
B	1	THERMOSTAT KNOB, BLACK	060612
C	1	GAS FRYER THERMOSTAT 14 BB, TS, IFM, CPU 10x11, 18" and Larger	035574 035575
D	1	SWITCH MELT-IDLE-FRY	032829
E	1	HIGH LIMIT (Resettable) *BOTTOM MOUNT *BACK MOUNT	1-800-KEATING 034357 004341
F	1	FLAME SWITCH	038563
G	1	SWITCH ROCKER WHITE MOMENTARY (Push to Light)	032297
H	1	INDICATING LIGHT AMBER	021254
J	1	SWITCH ROCKER WHITE (Replacement Kit)	058328

*LOCATED ON REAR DRAIN UNITS ONLY

CONTROL PANEL BB GAS - SERIES 2006

CONTROL PANEL FRONT

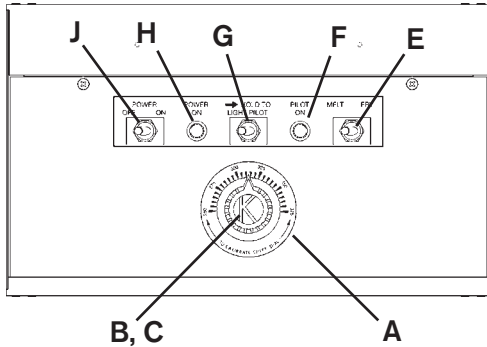

CONTROL PANEL BB SPARK IGNITION - SERIES 2006

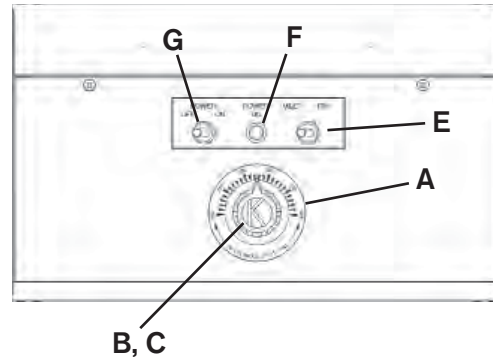

BACK PANEL - REAR DRAIN UNIT

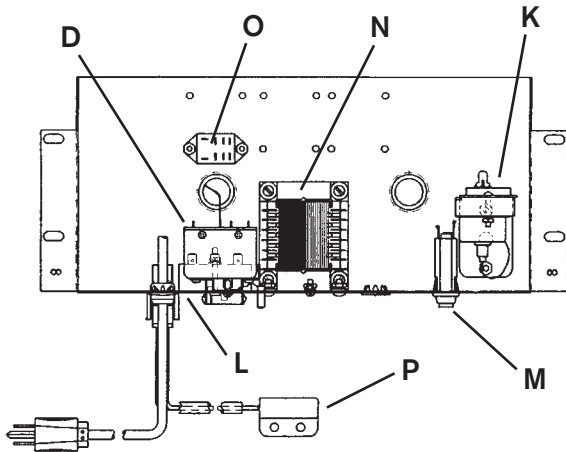

BACK PANEL - REAR DRAIN UNIT

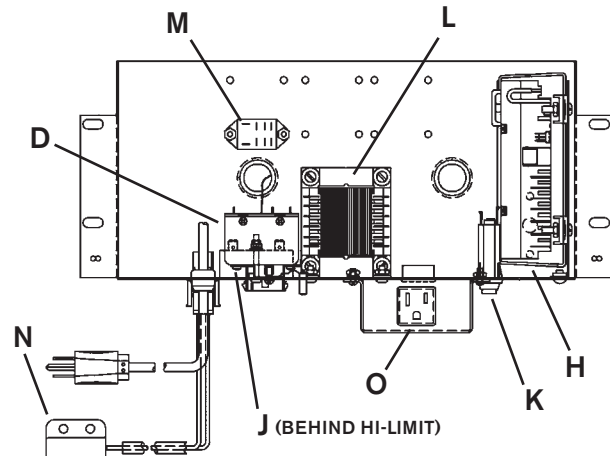

ITEM	QTY	DESCRIPTION	P/N
A	1	THERMOSTAT DIAL PLATE 250°- 375°F	058037
B	1	THERMOSTAT KNOB, BLACK	060612
C	1	GAS FRYER THERMOSTAT 14 BB, TS, IFM, CPU	035574
		10x11, 18BB and Larger	035575
D		HIGH LIMIT (Resettable)	1-800-KEATING
		*BOTTOM MOUNT	034357
		*BACK MOUNT	004341
E	1	SWITCH TOGGLE MELT-FRY	059143
F	1	INDICATING LIGHT AMBER	056588
G	1	SWITCH TOGGLE PILOT	059142
H	1	INDICATING LIGHT CLEAR	057863
J	1	SWITCH TOGGLE POWER	059141
K	1	FLAME SWITCH	038563
L	1	FAT MELT	037470
M	1	CIRCUIT BREAKER 3 AMP 1P	053338
N	1	TRANSFORMER 24VAC	024032
O*	1	RELAY DPDT 24VAC	030844
P**	1	MAGNETIC SAFETY SWITCH	053777
Q*	1	RECEPTACLE 125V (not shown)	011505

*LOCATED ON REAR DRAIN UNITS ONLY
**ON 34x24 REAR DRAIN MODEL - QTY 2

ITEM	QTY	DESCRIPTION	P/N
A	1	THERMOSTAT DIAL PLATE 250°- 375°F	058037
B	1	THERMOSTAT KNOB, BLACK	060612
C	1	GAS FRYER THERMOSTAT 14 BB, TS, IFM, CPU	035574
		10x11, 18" and Larger	035575
D		HIGH LIMIT (Resettable)	1-800-KEATING
		*BOTTOM MOUNT	034357
		*BACK MOUNT	004341
E	1	SWITCH TOGGLE MELT-FRY	059143
F	1	INDICATING LIGHT CLEAR	057863
G	1	SWITCH TOGGLE POWER	059141
H	1	SPARK IGNITION MODULE 24V	058439
		(Check pages 29-30 for accuracy)	
J	1	FAT MELT CONTROL	038168
K	1	CIRCUIT BREAKER 3AMP 1P	053338
L	1	TRANSFORMER 24VAC	024032
M*	1	RELAY DPDT 24VAC	030844
N**	1	MAGNETIC SAFETY SWITCH	053777
O*	1	RECEPTACLE 125V (not shown)	011505

*LOCATED ON REAR DRAIN UNITS ONLY
**ON 34x24 REAR DRAIN MODEL - QTY 2

**CONTROL PANEL BB SPARK IGNITION -
SERIES 2006 (Continued)**

BACK PANEL - FRONT DRAIN UNIT

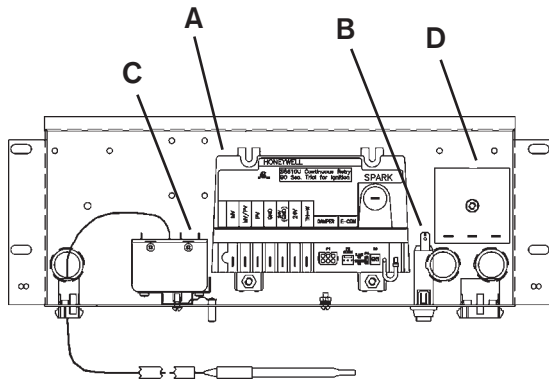

ITEM	QTY	DESCRIPTION	P/N
A	1	SPARK IGNITION MODULE 24 (Check pages 29-30 for accuracy)	058439
B	1	CIRCUIT BREAKER 3AMP 1P	053338
C	1	HIGH LIMIT (Resettable) *BOTTOM MOUNT *BACK MOUNT	1-800-KEATING 034357 004341
D	1	FAT MELT CONTROL	038168

*LOCATED ON REAR DRAIN UNITS ONLY

CONTROL PANEL TS GAS - SERIES 2000

CONTROL PANEL FRONT

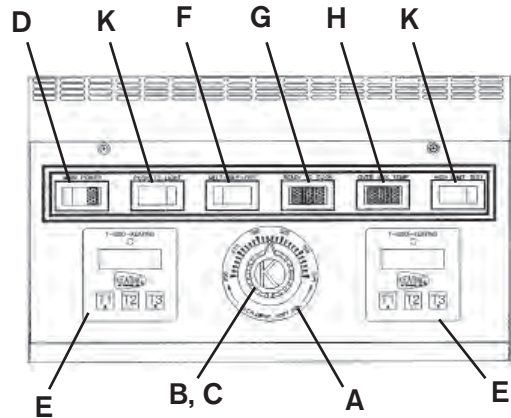

BACK PANEL - REAR DRAIN UNIT

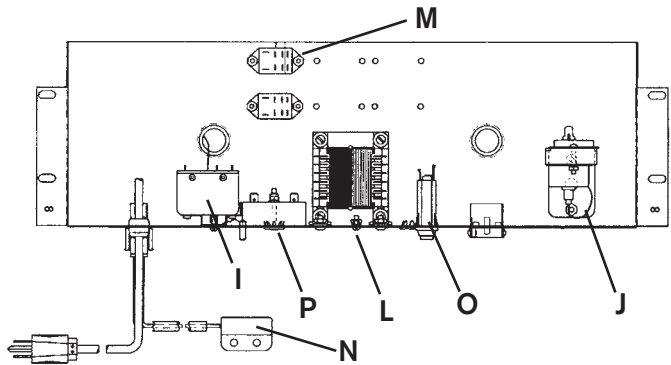

ITEM	QTY	DESCRIPTION	P/N
A	1	THERMOSTAT DIAL PLATE 250°-375°F	058037
B	1	THERMOSTAT KNOB, BLACK	060612
C	1	GAS FRYER THERMOSTAT 14 BB, TS, IFM, CPU 10x11, 18" and Larger	035574 035575
D	1	SWITCH ROCKER WHITE (Replacement Kit)	058328
E	2	DIGITAL TIMER 24V	056921
F		SWITCH MELT-IDLE-FRY	032829
G	1	INDICATING LIGHT GREEN	021255
H	1	INDICATING LIGHT RED	021209
I	1	HIGH LIMIT (Resettable)	034357
J	1	FLAME SWITCH	038563
K	2	SWITCH ROCKER WHITE MOMENTARY (Push to Light)	032297
L	1	TRANSFORMER 24VAC	024032
M*	2	RELAY DPDT 24VAC	030844
N*	1	MAGNETIC DRAIN SWITCH	053777
O	1	CIRCUIT BREAKER 3AMP 1P	053338
P	1	FAT MELT	037470

*LOCATED ON REAR DRAIN UNITS ONLY

CONTROL PANEL TS GAS - SERIES 2006

CONTROL PANEL FRONT

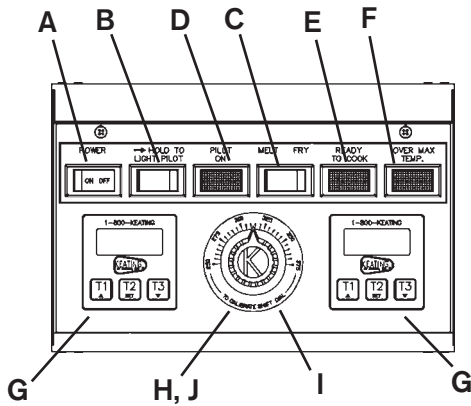

BACK PANEL - REAR DRAIN UNIT

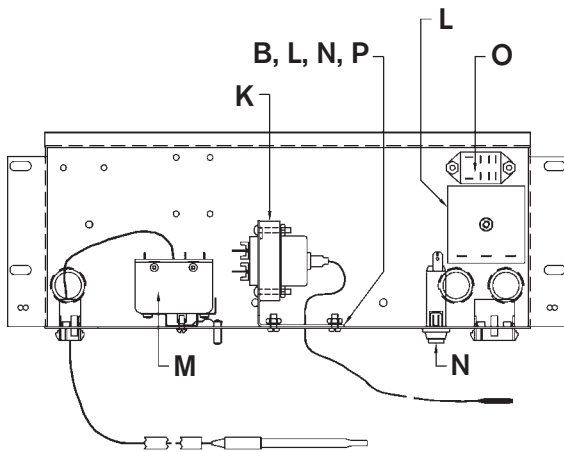

ITEM	QTY	DESCRIPTION	P/N
A	1	SWITCH ROCKER WHITE ON/OFF	035030
B	1	SWITCH ROCKER WHITE MOMENTARY	032297
C	1	SWITCH ROCKER WHITE MELT FRY	025726
D	1	INDICATING LIGHT AMBER	021254
E	1	INDICATING LIGHT GREEN	021255
F	1	INDICATING LIGHT RED	021209
G	2	DIGITAL TIMER 24V	056921
H	1	GAS FRYER THERMOSTAT 14 BB, TS, IFM, CPU	035574
		10x11, 18" and Larger	035575
I	1	THERMOSTAT DIAL PLATE 250°-375°F	058037
J	1	THERMOSTAT KNOB, BLACK	060612
K	1	FLAME SWITCH	038563
L	1	FAT MELT	037471
M	1	HI-LIMIT (Resettable)	034357
N	1	CIRCUIT BREAKER 3AMP 1P	053338
O	1	RELAY DPDT 24VAC	030844
P*	1	MAGNETIC DRAIN SWITCH	053777
Q**	1	CIRCUIT BREAKER 4AMP 1P	058219
R*	1	RECEPTACLE 125V	011505

*NOT SHOWN - LOCATED ON REAR DRAIN UNITS ONLY
 **NOT SHOWN - BASKET-LIFT UNITS ONLY

CONTROL PANEL TS GAS FOR 34x24 MODEL - SERIES 2007 FOR ALL OTHER MODELS - SERIES 2009

CONTROL PANEL FRONT

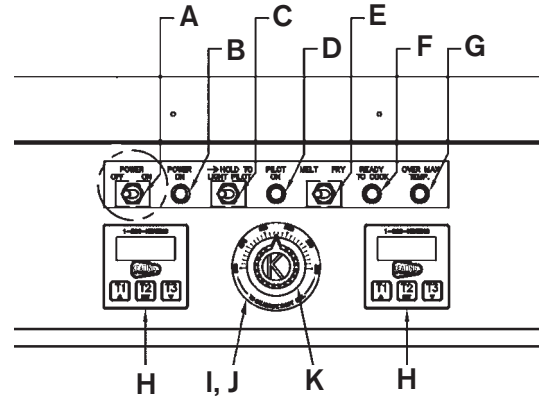

BACK PANEL - FRONT DRAIN UNIT

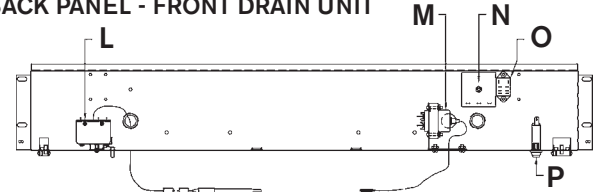

BACK PANEL - REAR DRAIN UNIT

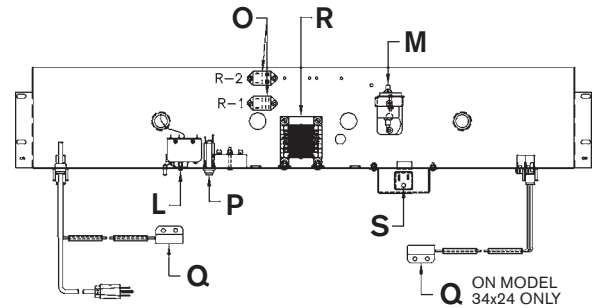

ITEM	QTY	DESCRIPTION	P/N
A	1	SWITCH TOGGLE POWER	059141
B	1	INDICATING LIGHT CLEAR	057863
C	1	SWITCH TOGGLE PILOT	059142
D	1	INDICATING LIGHT AMBER	056588
E	1	SWITCH TOGGLE MELT - FRY	059143
F	1	INDICATING LIGHT GREEN	056587
G	1	INDICATING LIGHT RED	057861
H	2	TIMER DIGITAL 24V	056921
I	1	THERMOSTAT	035575
J	1	THERMOSTAT KNOB, BLACK	060612
K	1	THERMOSTAT DIAL PLATE 250°-375°F	058037
L	1	HIGH LIMIT (Resettable)	034357
M	1	FLAME SWITCH	038563
N	1	FAT MELT	034271
O	1	RELAY DPDT 24VAC	030844
P	1	CIRCUIT BREAKER 3 AMP 1 P	053338
Q**	1	MAGNETIC DRAIN SWITCH	053777
R*	1	TRANSFORMER 24VAC	024032
S*	1	RECEPTACLE 125V	011505
T***	1	CIRCUIT BREAKER 4 AMP 1 P	058219

*LOCATED ON REAR DRAIN UNITS ONLY
 **QTY 2 FOR 34x24 MODELS
 *** NOT SHOWN - LOCATED ON BASKET-LIFT UNITS ONLY

**CONTROL PANEL TS SPARK IGNITION -
SERIES 2006**

CONTROL PANEL FRONT

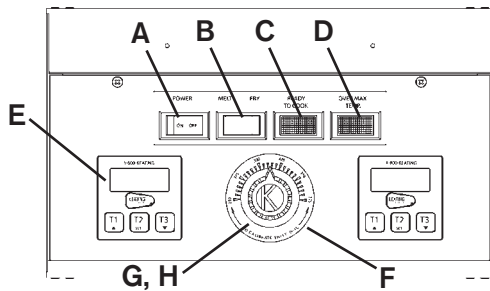

BACK PANEL - FRONT DRAIN UNIT

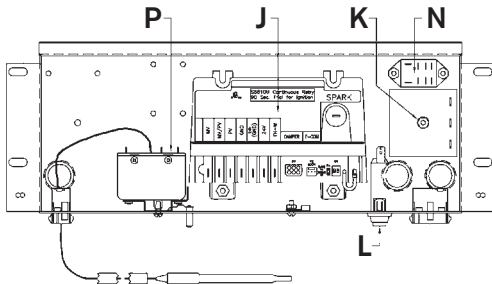

BACK PANEL - REAR DRAIN UNIT

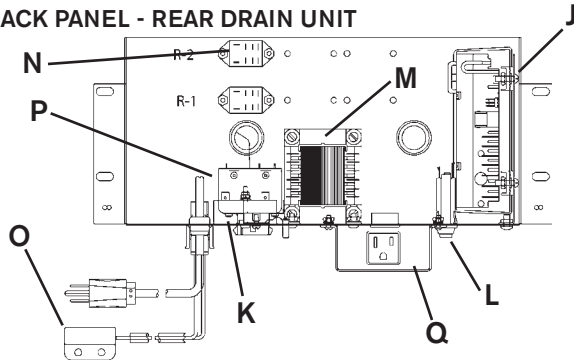

ITEM	QTY	DESCRIPTION	P/N
		SWITCH ROCKER WHITE	
A	1	ON/OFF	035030
B	1	MELT-FRY	025726
C	1	INDICATING LIGHT GREEN	021255
D	1	INDICATING LIGHT RED	021209
E	2	DIGITAL TIMER 24V	056921
F	1	THERMOSTAT DIAL PLATE 250°-375°F	058037
G	1	THERMOSTAT KNOB, BLACK	060612
H	1	GAS FRYER THERMOSTAT 14 BB, TS, IFM, CPU	035574
		10x11, 18" and Larger	035575
J	1	SPARK IGNITION MODULE 24V (Check Pages 29-30 for accuracy)	058439
K	1	FAT MELT	037470
L	2	CIRCUIT BREAKER 3AMP 1P	053338
M*	1	TRANSFORMER 24VAC	024032
N*	2	RELAY DPDT 24VAC	030844
O*	1	MAGNETIC DRAIN SWITCH	053777
P	1	HIGH LIMIT (Resettable)	034357
Q*	1	RECEPTACLE 120V	011505
R**	1	CIRCUIT BREAKER 4AMP 1P	058219

*LOCATED ON REAR DRAIN UNITS ONLY

**NOT SHOWN - LOCATED ON BASKET-LIFT UNITS ONLY

**CONTROL PANEL TS SPARK IGNITION -
FOR 34x24 MODEL - SERIES 2007
FOR ALL OTHER MODELS - SERIES 2009**

CONTROL PANEL FRONT

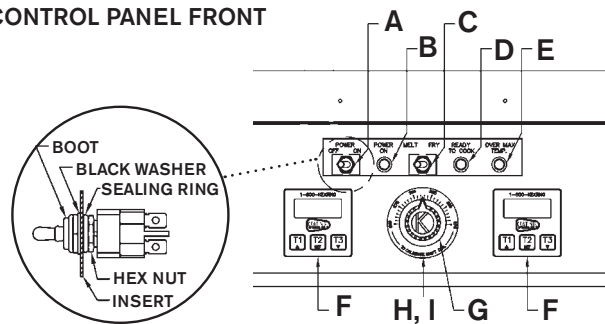

BACK PANEL - FRONT DRAIN UNIT

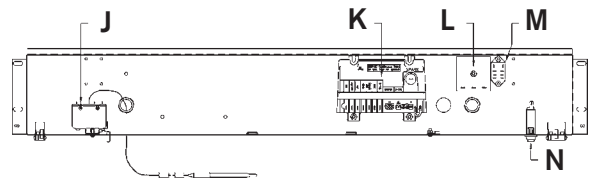

BACK PANEL - REAR DRAIN UNIT

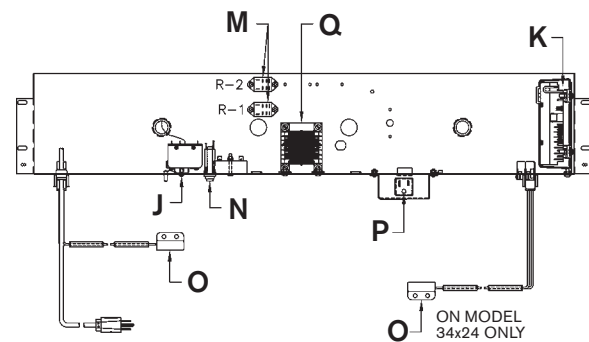

ITEM	QTY	DESCRIPTION	P/N
A	1	SWITCH TOGGLE POWER	059141
B	1	INDICATING LIGHT CLEAR	057863
C	1	SWITCH TOGGLE MELT-FRY	059143
D	1	INDICATING LIGHT GREEN	056587
E	1	INDICATING LIGHT RED	057861
F	2	DIGITAL TIMER 24V	056921
G	1	GAS FRYER THERMOSTAT	035575
H	1	THERMOSTAT DIAL PLATE 250°-375°F	058037
I	1	THERMOSTAT KNOB, BLACK	060612
J	1	HIGH LIMIT (Resettable)	034357
K	1	SPARK IGNITION MODULE 24V (Check Pages 29-30 for accuracy)	058439
L	1	FAT MELT	037470
M	1	RELAY DPDT 24VAC	030844
N	1	CIRCUIT BREAKER 3AMP 1P	053338
O**	1	MAGNETIC DRAIN SWITCH	053777
P*	1	RECEPTACLE 120V	011505
Q*	1	TRANSFORMER 24VAC	024032
R***	1	CIRCUIT BREAKER 4AMP 1P	058219

*LOCATED ON REAR DRAIN UNITS ONLY

**QTY 2 FOR 34x24 MODELS

***NOT SHOWN - LOCATED ON BASKET-LIFT UNITS ONLY

CPU CONTROL PANEL - SERIES 2007

CONTROL PANEL FRONT

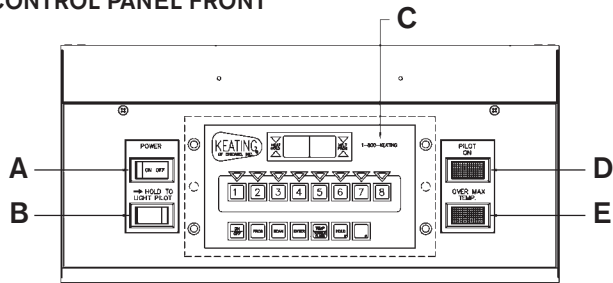

BACK PANEL - FRONT DRAIN UNIT

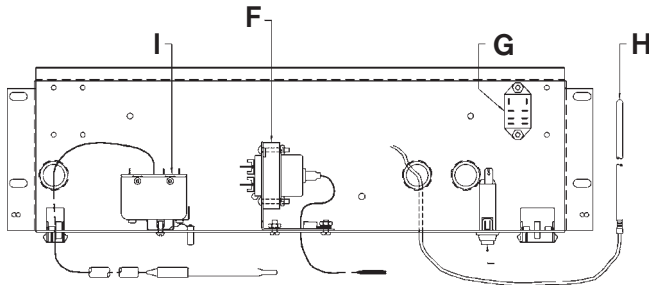

BACK PANEL - REAR DRAIN UNIT

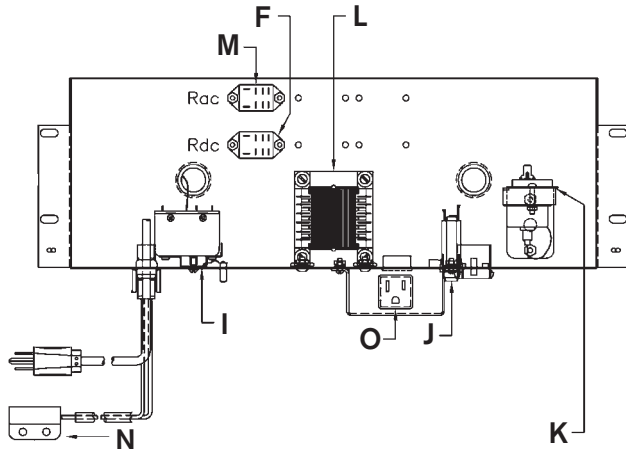

ITEM	QTY	DESCRIPTION	P/N
		SWITCH ROCKER WHITE	
A	1	ON/OFF	035030
B	1	MOMENTARY	032297
C	1	COMPUTER	031125
D	1	INDICATING LIGHT AMBER	021254
E	1	INDICATING LIGHT RED	021209
F	1	FLAME SWITCH	038563
G	1	RELAY DPDT 24VDC	017673
H	1	COMPUTER PROBE	004776
I	1	HIGH LIMIT (Resettable)	034357
J	1	CIRCUIT BREAKER 3AMP 1P	053338
K*	1	FLAME SWITCH	038563
L*	1	TRANSFORMER 24VAC	024032
M*	1	RELAY DPDT 24VAC	030844
N*	1	MAGNETIC DRAIN SWITCH	053777
O*	1	RECEPTACLE 120V	011505
P**	1	CIRCUIT BREAKER 4AMP 1P	058219

*LOCATED ON REAR DRAIN UNITS ONLY

**NOT SHOWN - LOCATED ON BASKET-LIFT UNITS ONLY

CPU CONTROL PANEL - SERIES 2010

CONTROL PANEL FRONT

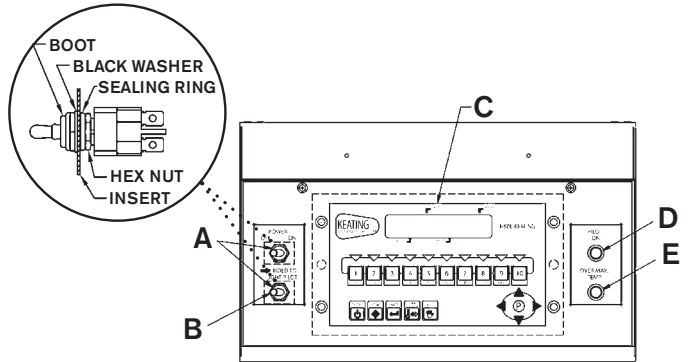

BACK PANEL - FRONT DRAIN UNIT

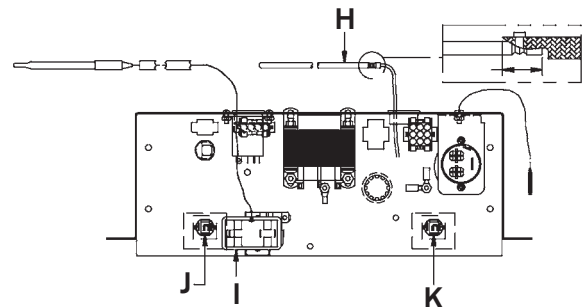

BACK PANEL - REAR DRAIN UNIT

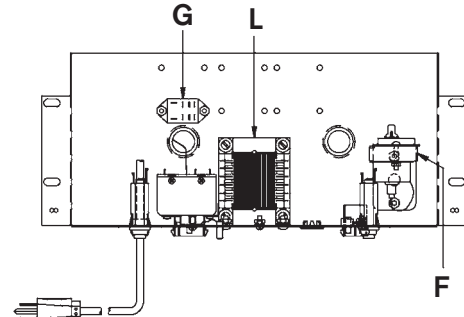

ITEM	QTY	DESCRIPTION	P/N
A	1	SWITCH TOGGLE POWER	056056
B	1	SWITCH TOGGLE PILOT	056057
C	1	COMPUTER	058896
D	1	LIGHT INDICATING ROUND AMBER	056588
E	1	LIGHT INDICATING ROUND RED	057861
F	1	FLAME SWITCH	038563
G	1	RELAY DPDT 24VDC	017673
H	1	COMPUTER PROBE	004776
I	1	HIGH LIMIT (Resettable)	032243
J	1	CIRCUIT BRKR 4 AMP 1 POLE 250V	058219
K	1	CIRCUIT BRKR 3 AMP 1 POLE 250V	053338
L	1	TRANSFORMER STEPDOWN 24VAC 80VA	024032

SPARK IGNITION DESIGN VARIATIONS

Design Valid Approx. 1994 - 2002

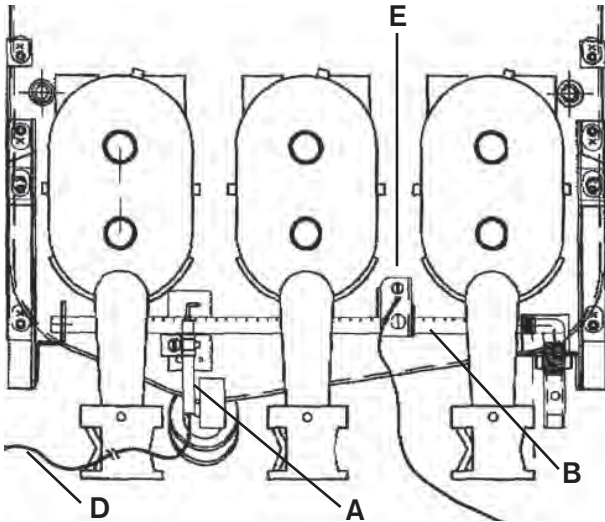

ITEM	QTY	DESCRIPTION	P/N
A	1	SPARK IGNITION ELECTRODE	058591
B	1	RUNNER PILOT TUBE	
		10x11	019796
		14"	019394
		18"	005610
		20"	005611
		24"	
		34x24	010768
C*	1	SPARK IGNITION MODULE 24V	028620
D		SPARK ELECTRODE CABLE	N/A
E	2	FLAME SWITCH	037406

*NOT SHOWN

Design Valid Approx. Feb. 2002 - Sept. 2004

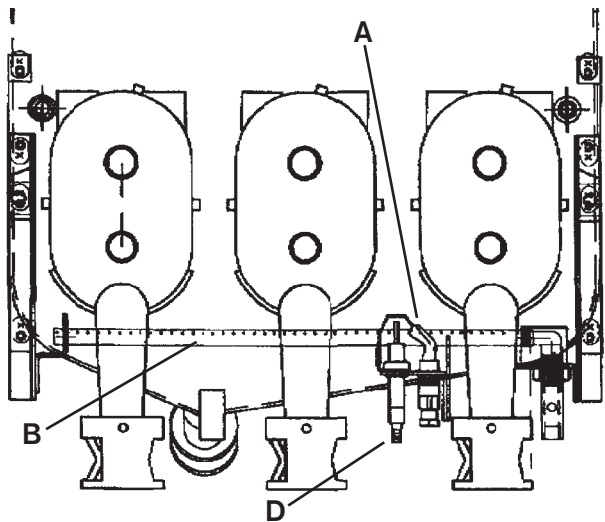

ITEM	QTY	DESCRIPTION	P/N
A	1	PILOT BURNER / ELECTRODE NG	033772
		PILOT BURNER / ELECTRODE LP	037436
B	1	RUNNER PILOT TUBE	
		10x11	
		14"	052891
		18"	052507
		20"	052892
		24"	052508
		34x24	
C*	1	SPARK IGNITION MODULE	058439
D*	1	SPARK ELECTRODE CABLE	037551

*NOT SHOWN

Design Valid Approx. Sept. 2004 - Current

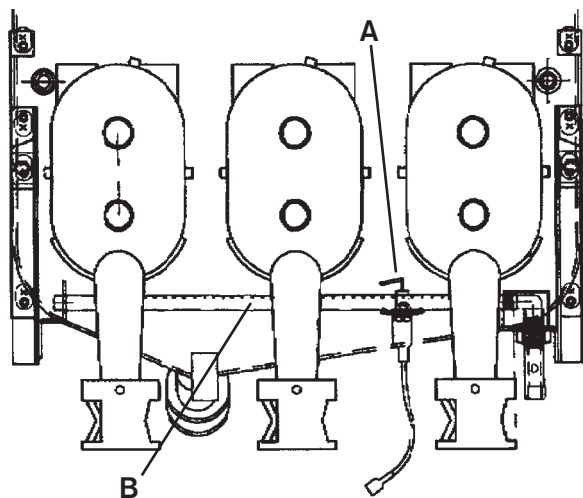

ITEM	QTY	DESCRIPTION	P/N
A	1	SPARK IGNITION ELECTRODE	030253
B	1	RUNNER PILOT TUBE	
		10x11	021656
		14"	028828
		18"	021658
		20"	021730
		24"	037623
		34x24	
C*	1	SPARK IGNITION MODULE	058439

*NOT SHOWN

BASKET LIFT POWER SUPPLY BOX & BASKET LIFT ASSEMBLY

(not shown to scale)

Figure 6

Basket Lift Power Supply Box

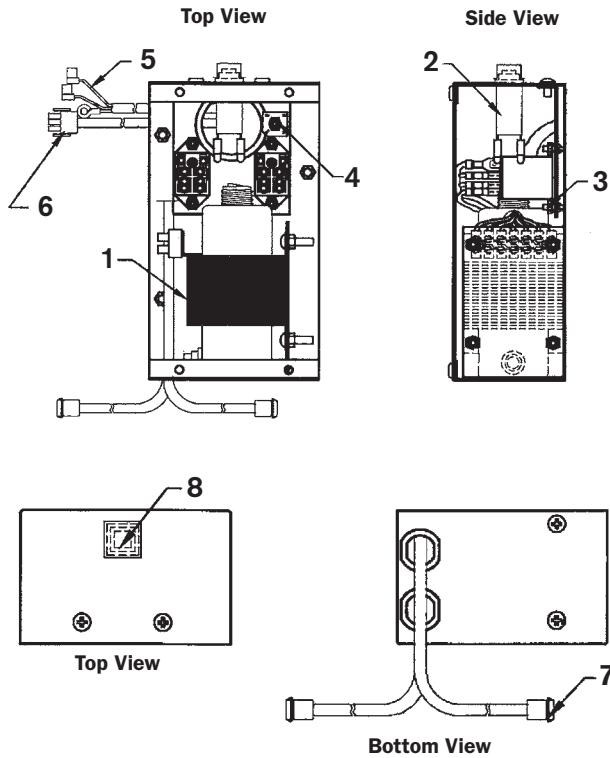
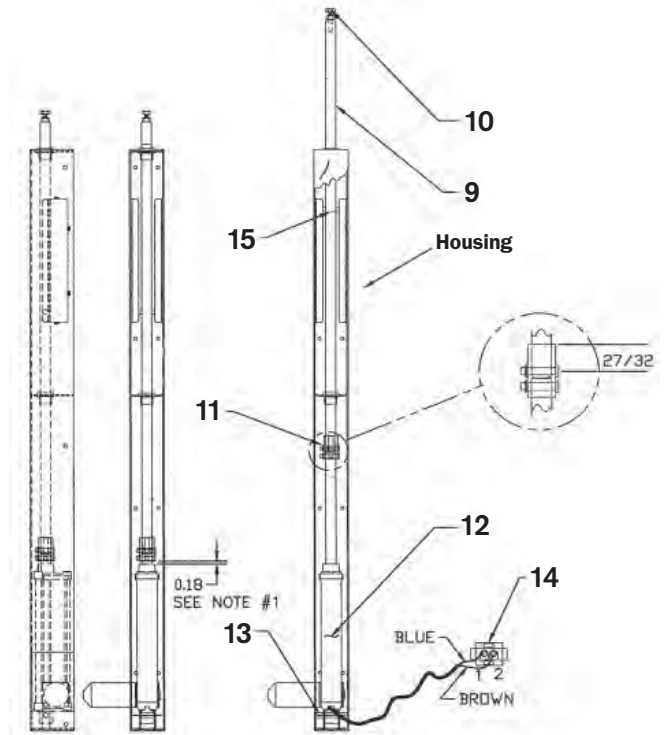

Figure 7

Basket Lift Assembly



- NOTES:**
1. A minimum distance of 3/16" and maximum distance of 1/4" should be maintained when actuator is at full downward stroke. Item 11 should never be bottomed on item 12 when in this location.
 2. Actuator shaft should travel 6 1/2" upward from lowest position.
 3. Distance is to be measured when actuator is powered.
 4. Apply light coating of food grade grease to Item 9 on entire shaft inside housing.

ITEM	DESCRIPTION	P/N	QTY
1	TRANSFORMER 120/208/240/480V	056036	1
2*	CIRCUIT BREAKER 3A/250V	053338	1
3	RELAY DPDT 24V AC	030844	2
4	RECTIFIER	038367	1
5	POWER CORD	021289	1
6	CONNECTION 3 CIRCUITS PLUG	032210	1
	CONNECTOR CONTACT PIN MALE	028309	3
7	CONNECTOR 2 CIRCUIT CAP	032207	2
	CONNECTOR CONTACT PIN FEMALE	028308	2
8	COVER FOR CIRCUIT BREAKER	054664	1
9	PUSH ROD	018096	1
10	SCREW 1/4"-20" x 1 1/4"	021091	1
	HEX NUT 1/4-20	016383	1
11	COUPLER ACTUATOR BL	054525	1
	RETAINING RING	054540	2
	PIN COUPLER ACTUATOR BL	054503	2
12	ACTUATOR 24V DC	054510	1
13	SHAFT ACTUATOR LOWER BL S/S	054522	1
14	CONNECTOR 2 CIRCUIT PLUG	032208	1
	CONNECTOR CONTACT PIN MALE	028309	2
15	PIN BASKET LIFT NON ROTATIONAL	054760	1

*This circuit breaker can be found under the control panel on newer units.

BASKET LIFT POWER SUPPLY BOX 2007 - CPU & NON-CPU

TOP VIEW

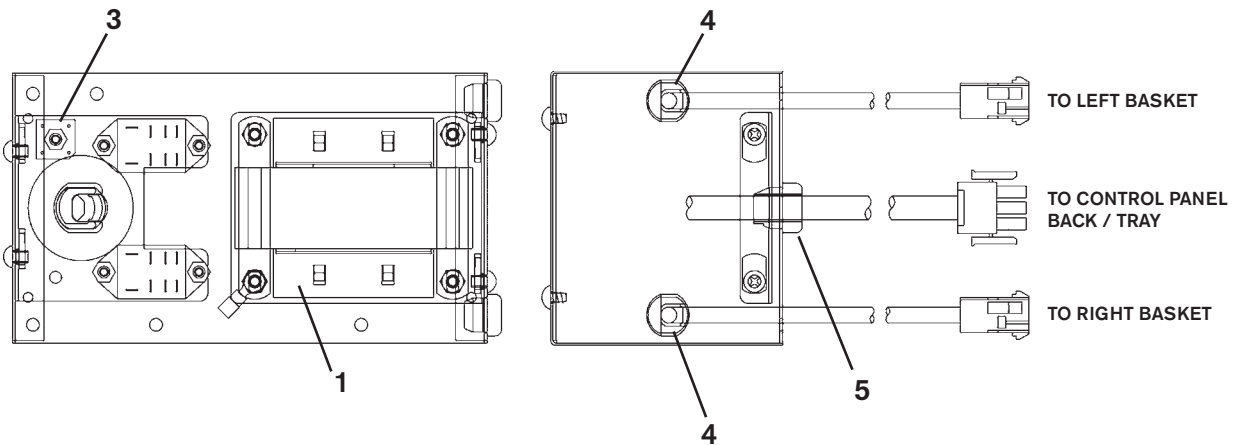

SIDE VIEW

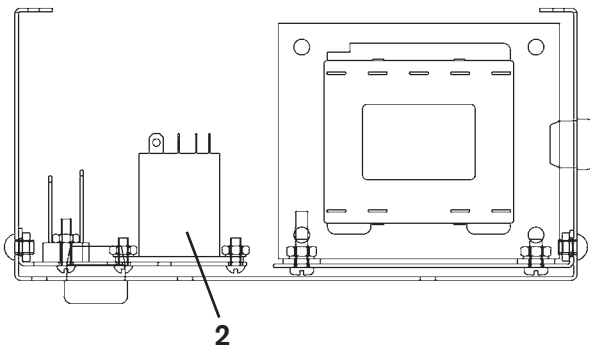

ITEM	DESCRIPTION	P/N	QTY
1	TRANSFORMER STEPDOWN 24VAC 100VA	058359	1
2	RELAY DPDT 24VAC RELAY DPDT 24VAC (CPU MODEL)	030844 017673	2 2
3	RECTIFIER 24VDC	018321	1
4	BUSHING STRAIN RELIEF 5/8" HOLE	000470	2
5	BUSHING STRAIN RELIEF 3/4" HOLE	033800	1

NOTE: Circuit breaker is located under the control panel.

ELECTRICAL BOX ASSEMBLY GAS FRYER SERIES 2000 - TS & BB ONLY

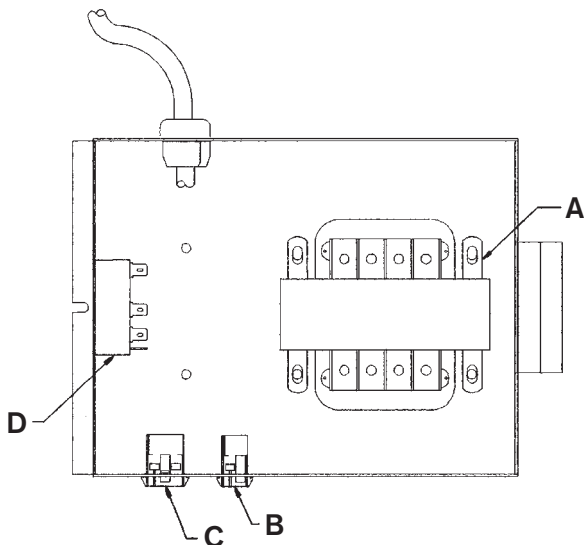

ITEM	DESCRIPTION	P/N	QTY
A	TRANSFORMER 120V/240V TO 24V	024032	1
B	2 PIN CONNECTOR	032207	1
C	9 PIN CONNECTOR	028303	1
D	FAT MELT 24V	037470	1

■ WIRING DIAGRAMS

(SEE INSIDE FRYER DOOR FOR CURRENT WIRING DIAGRAMS)

CM & AA 2000 ELECTRICAL ASSEMBLY FRONT DRAIN

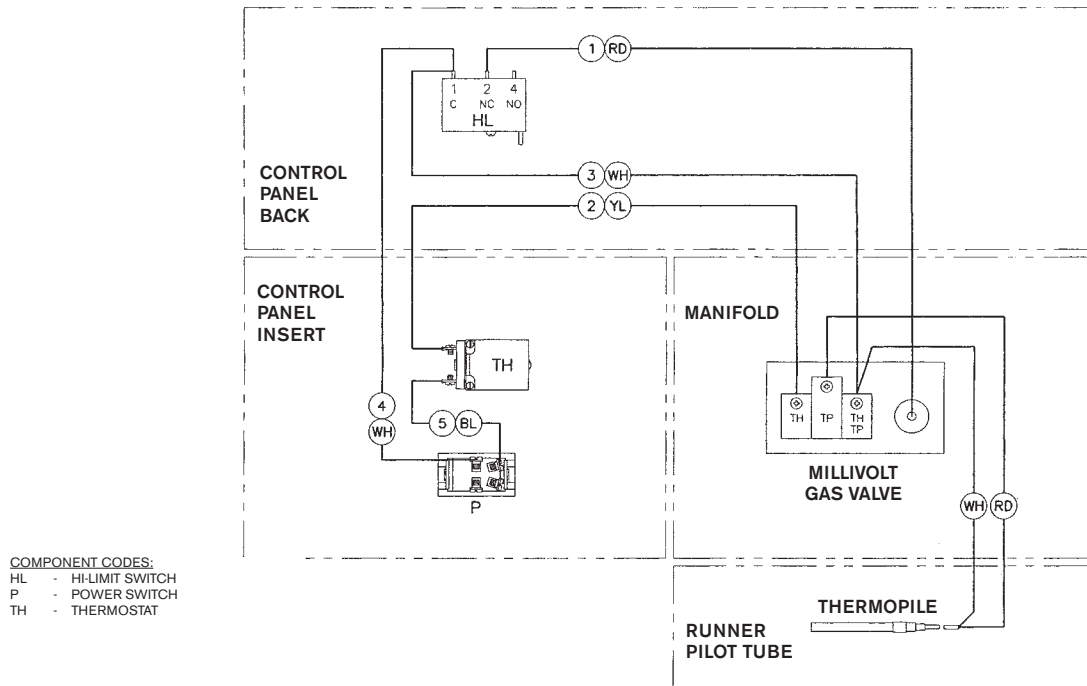

AA 2007 ELECTRICAL ASSEMBLY WITH SAFE & EASY® FILTER

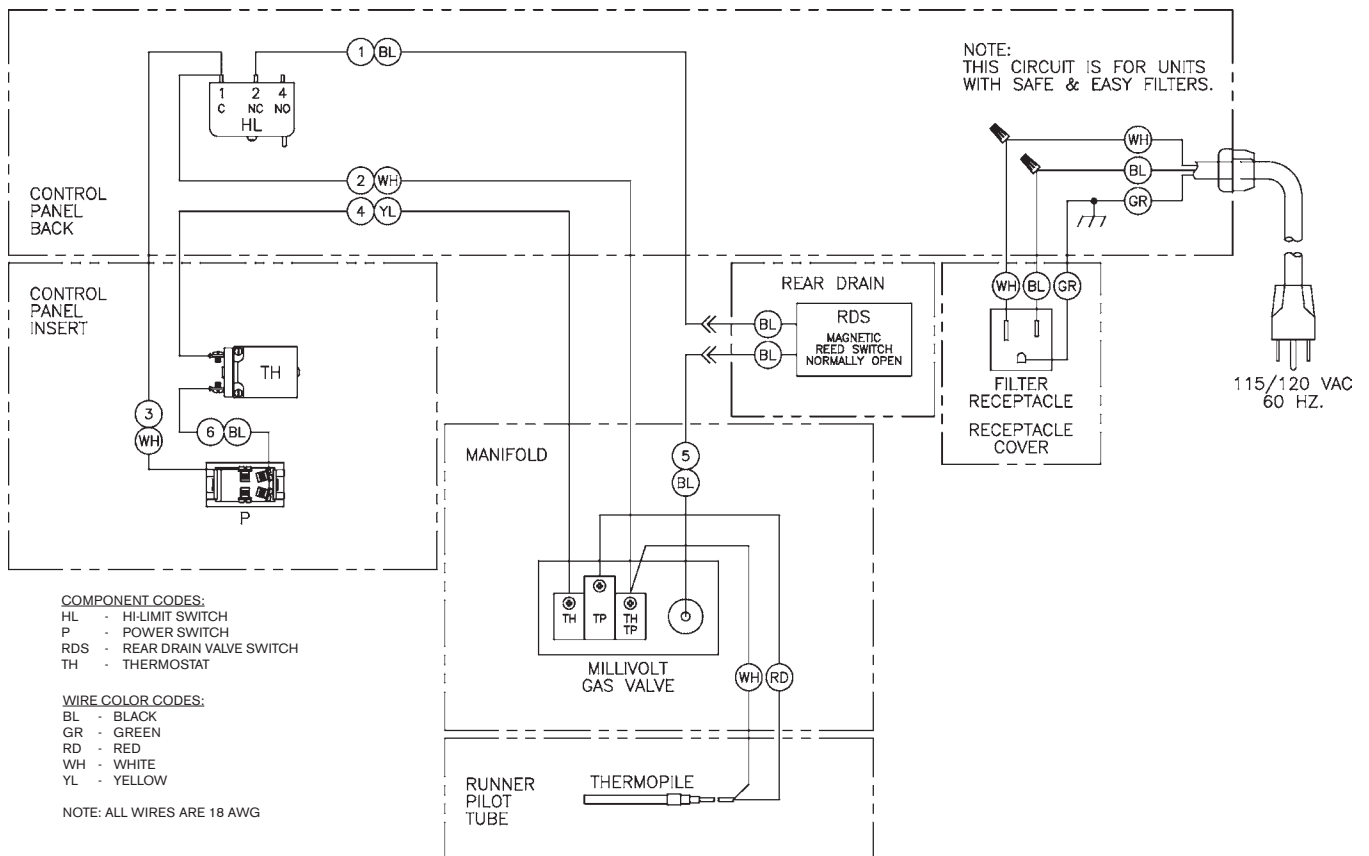

AA 2010 ELECTRICAL ASSEMBLY FRONT DRAIN

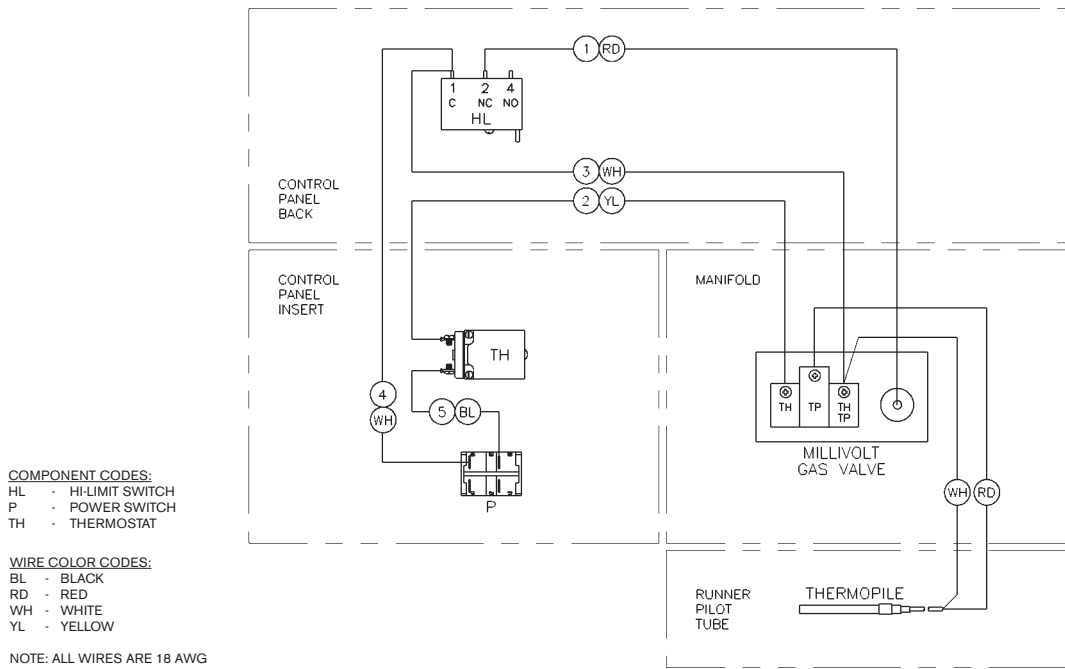

BB 2000 ELECTRICAL ASSEMBLY

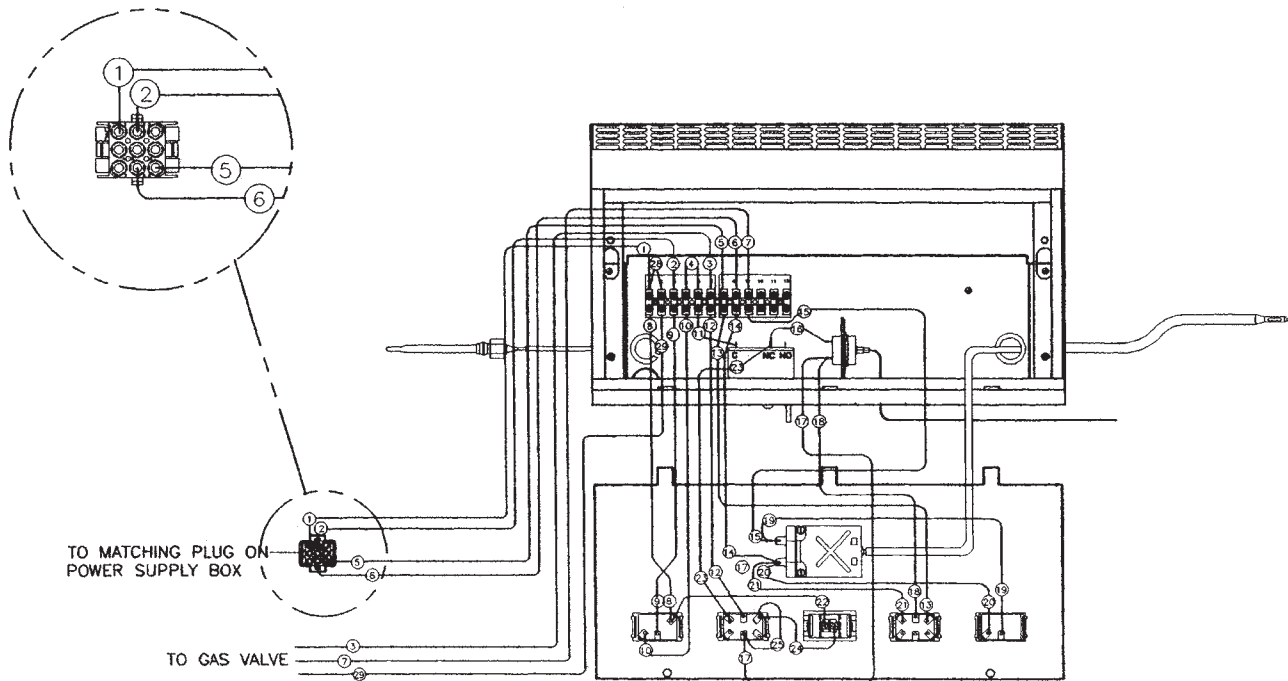

BB 2000 ELECTRICAL ASSEMBLY WITH SAFE & EASY® FILTER

(Electrical Assembly not Shown to Scale)

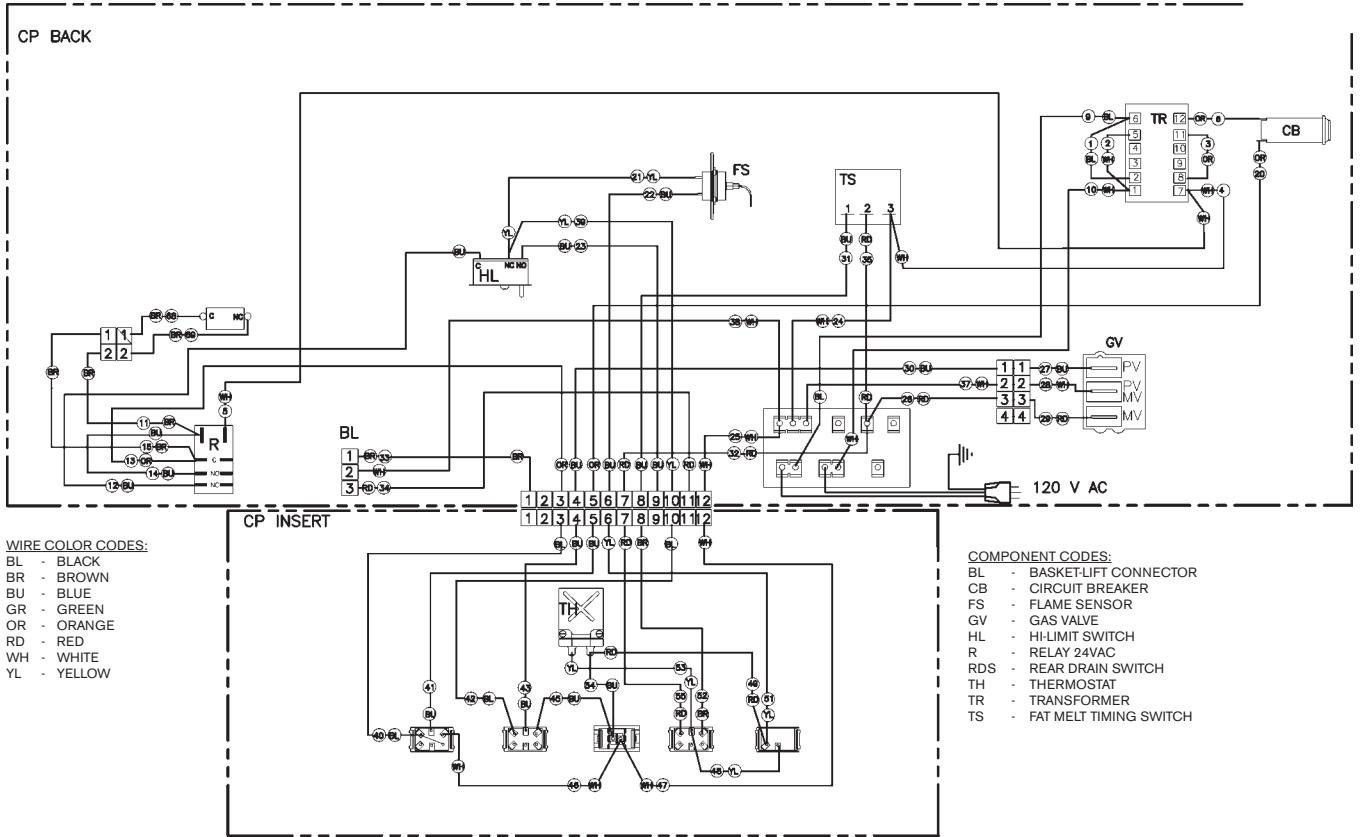

BB 2006 ELECTRICAL ASSEMBLY

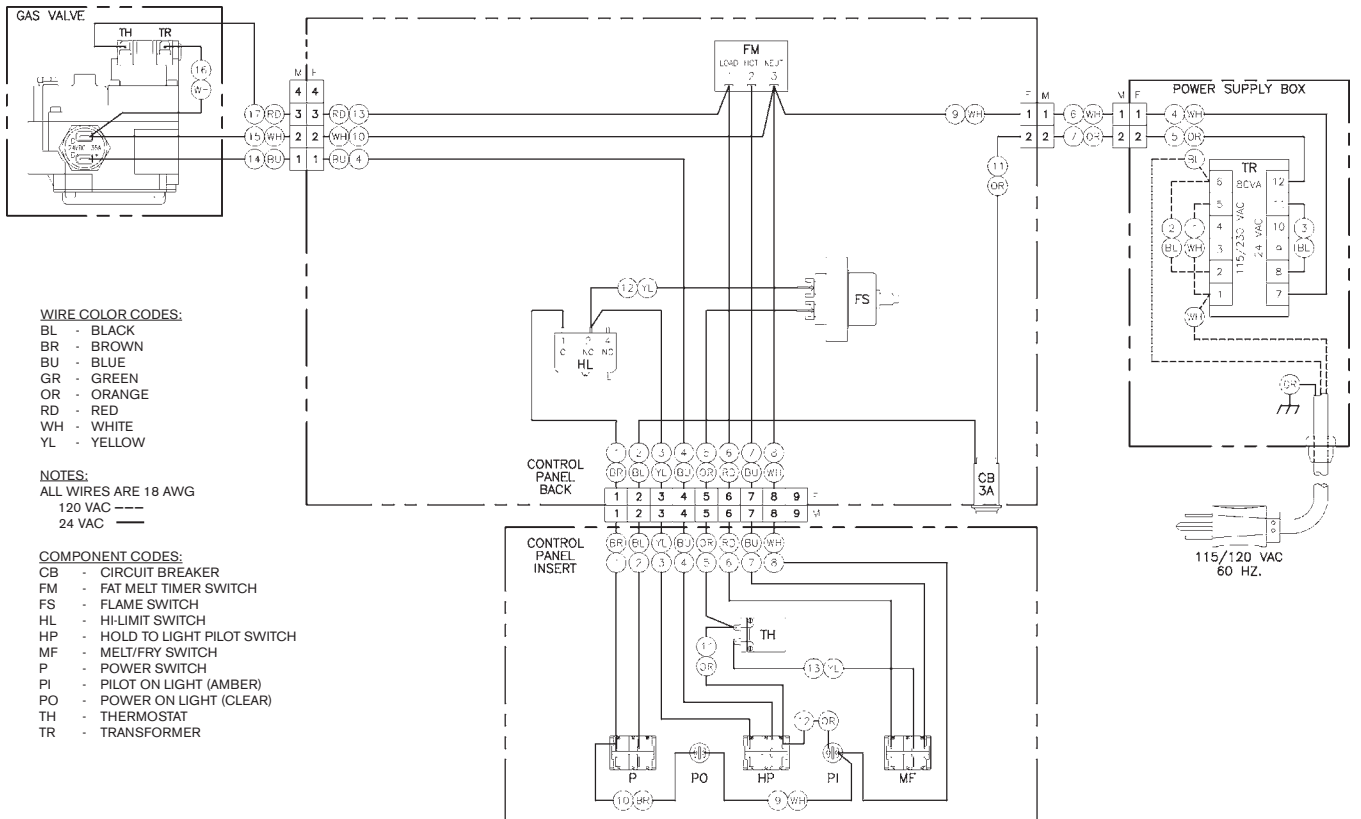

BB 2006 ELECTRICAL ASSEMBLY WITH SAFE & EASY® FILTER

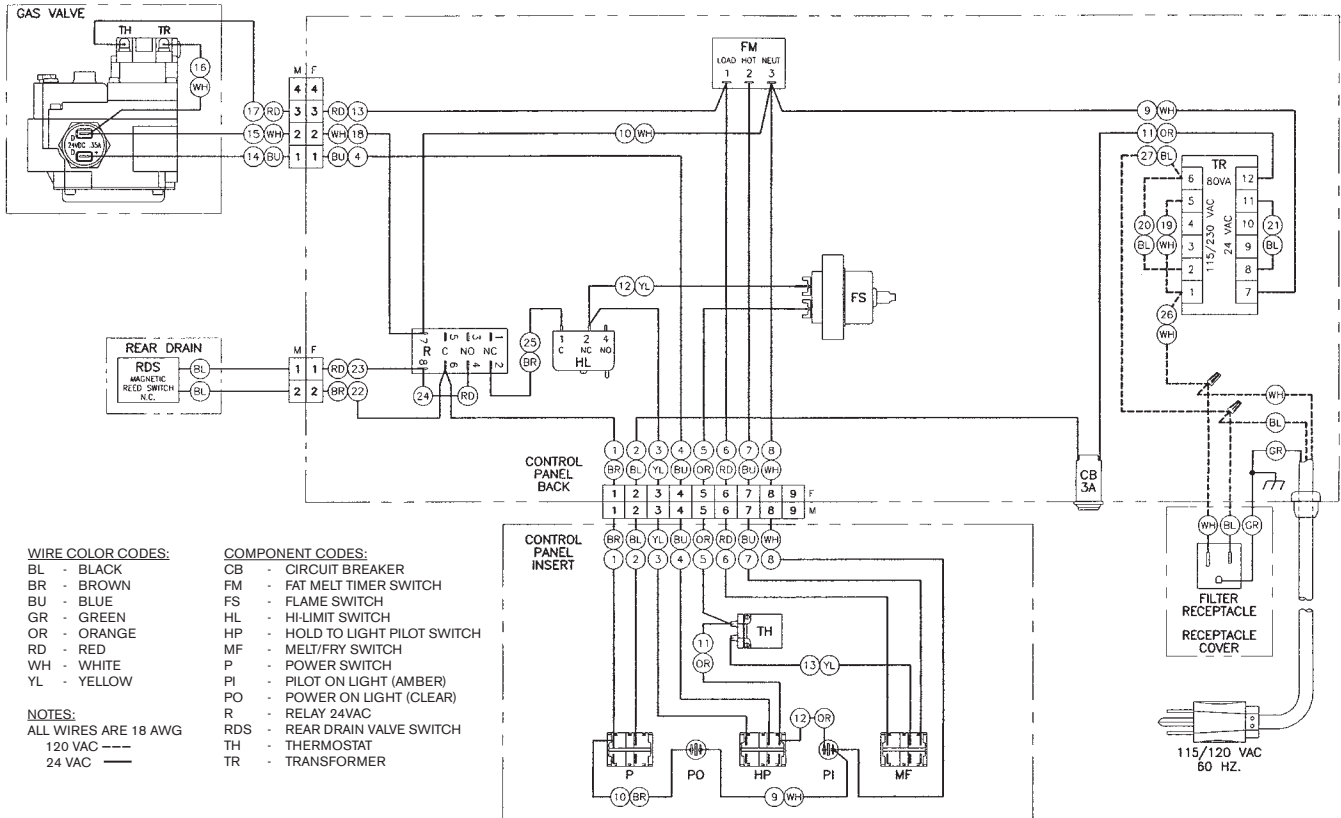

BB 2006 SPARK IGNITION WITH SAFE & EASY® FILTER

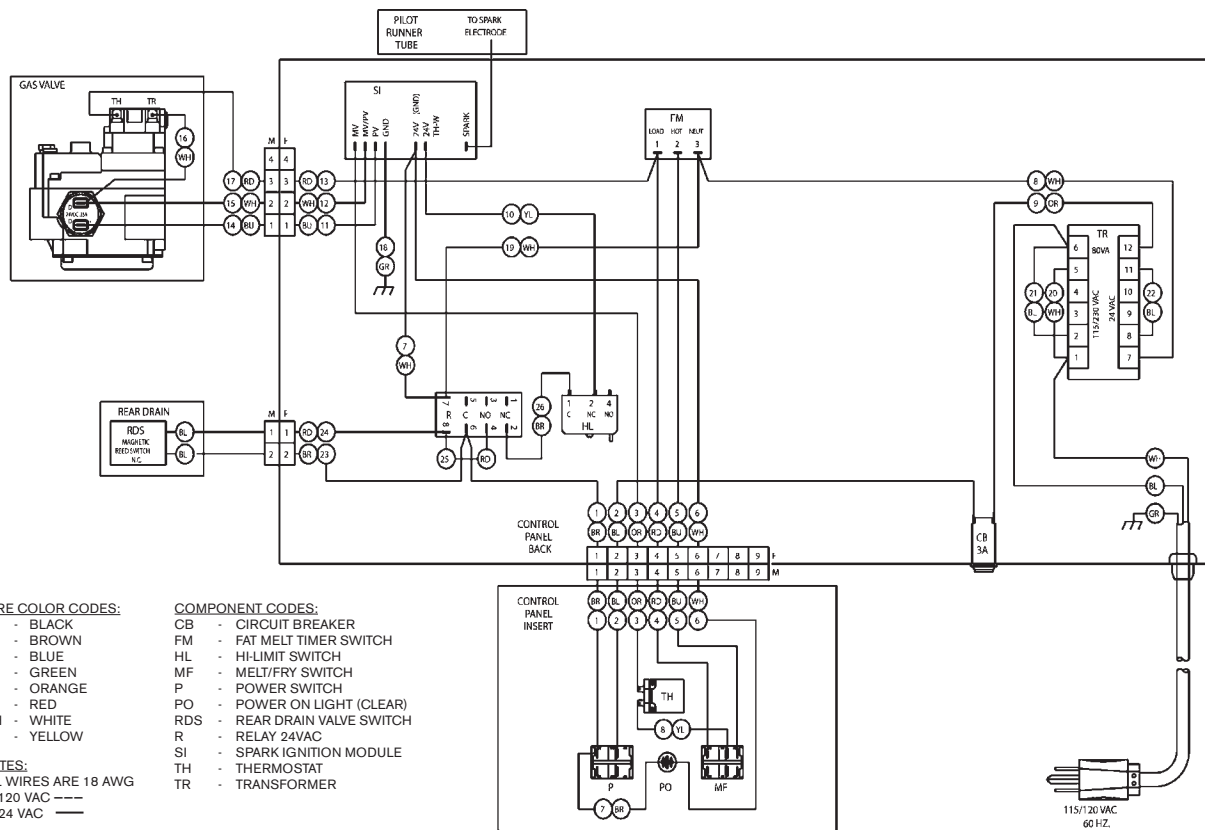

34x24 BB 2007 ELECTRICAL ASSEMBLY - FRONT DRAIN

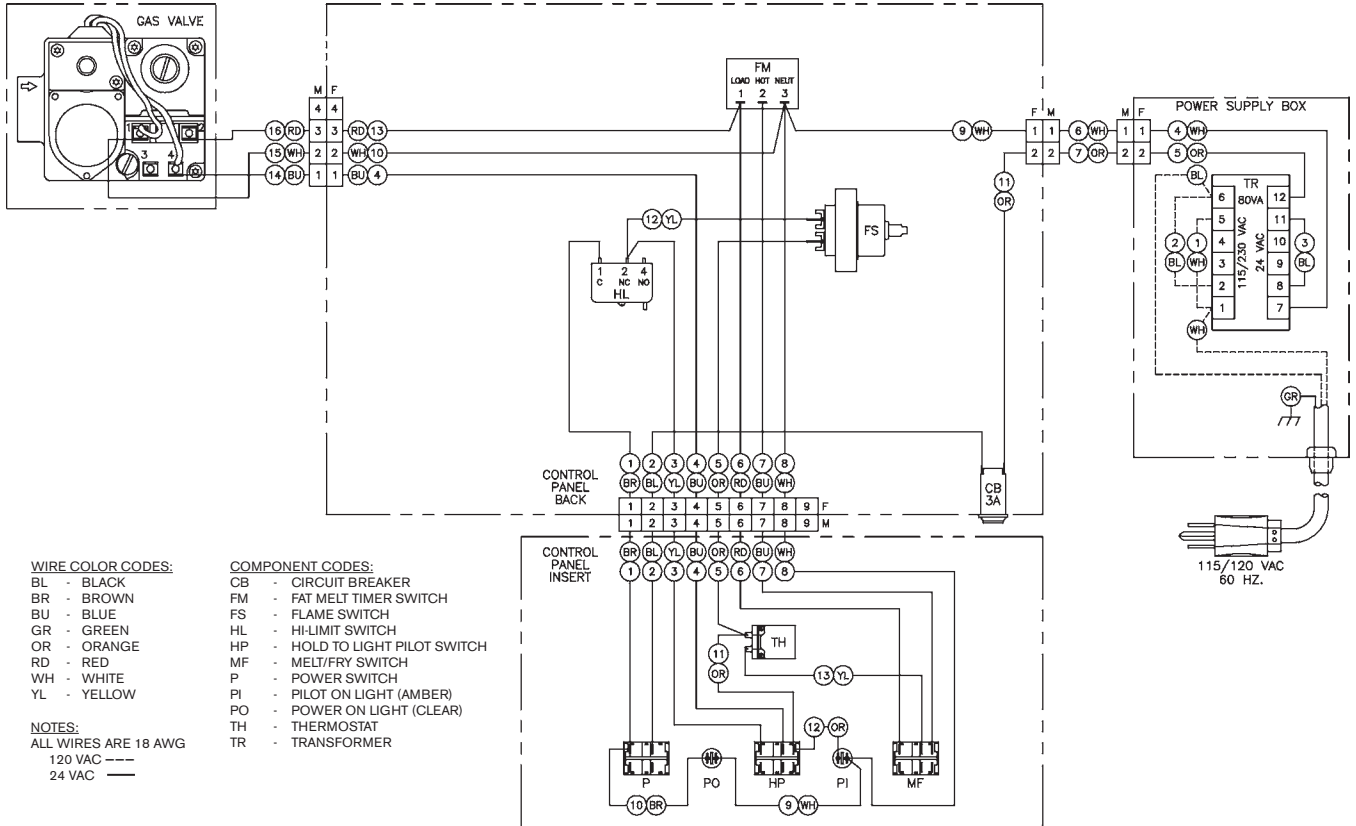

34x24 BB 2007 ELECTRICAL ASSEMBLY WITH SAFE & EASY® FILTER

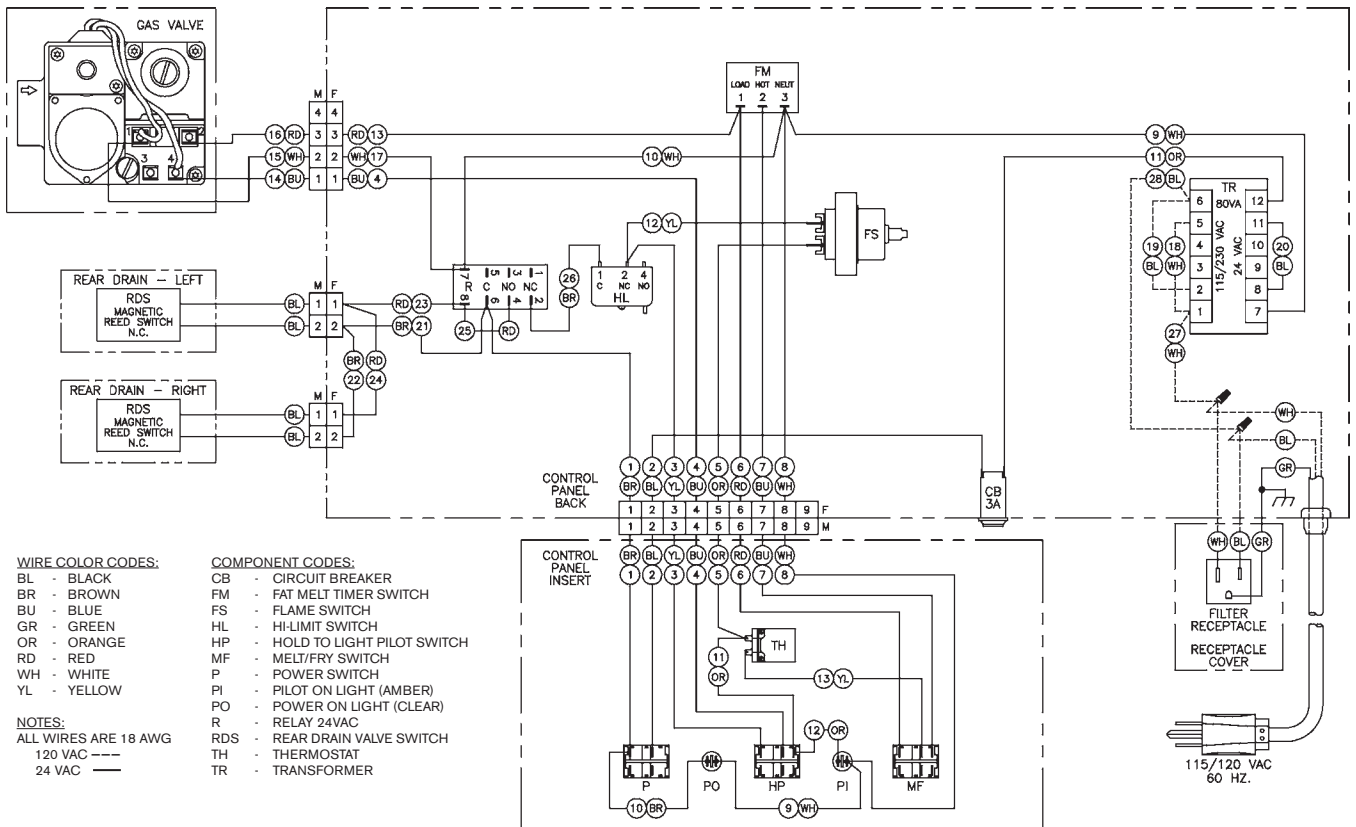

TS 2000 ELECTRICAL ASSEMBLY

(Electrical Assembly not Shown to Scale)

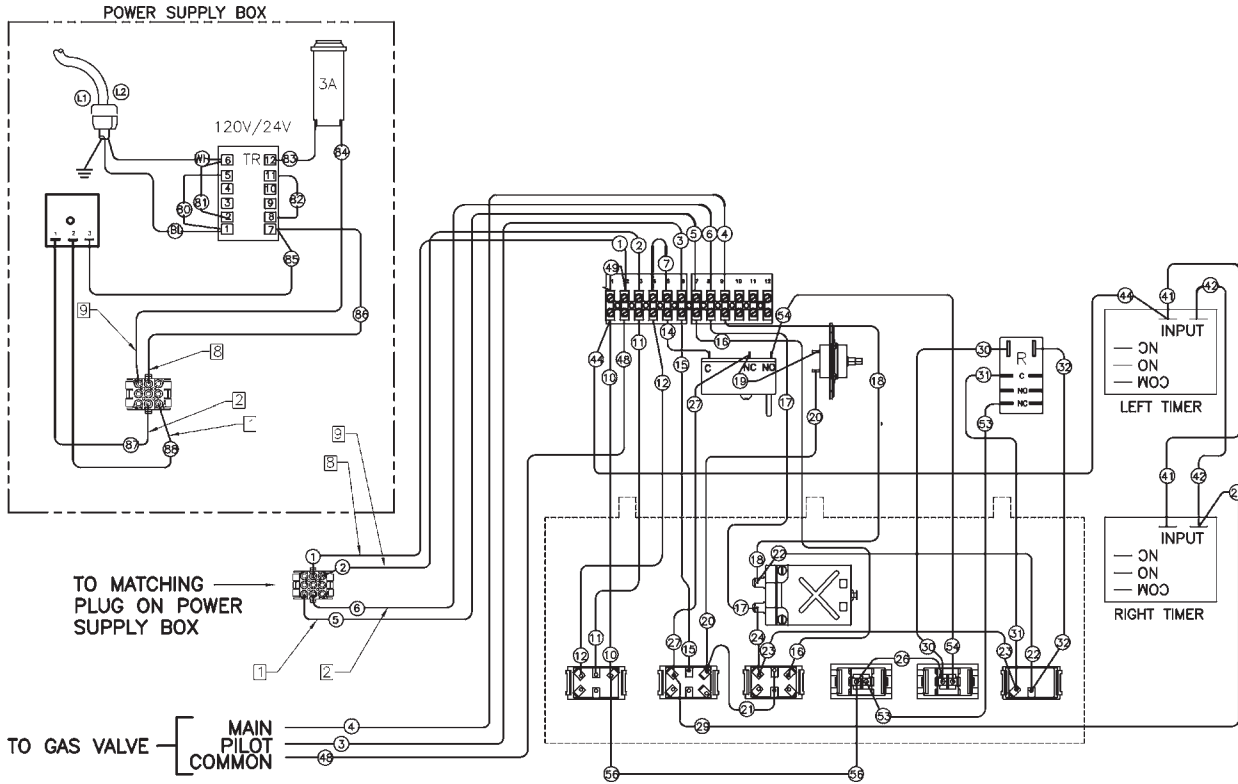

TS 2000 ELECTRICAL ASSEMBLY WITH SAFE & EASY® FILTER

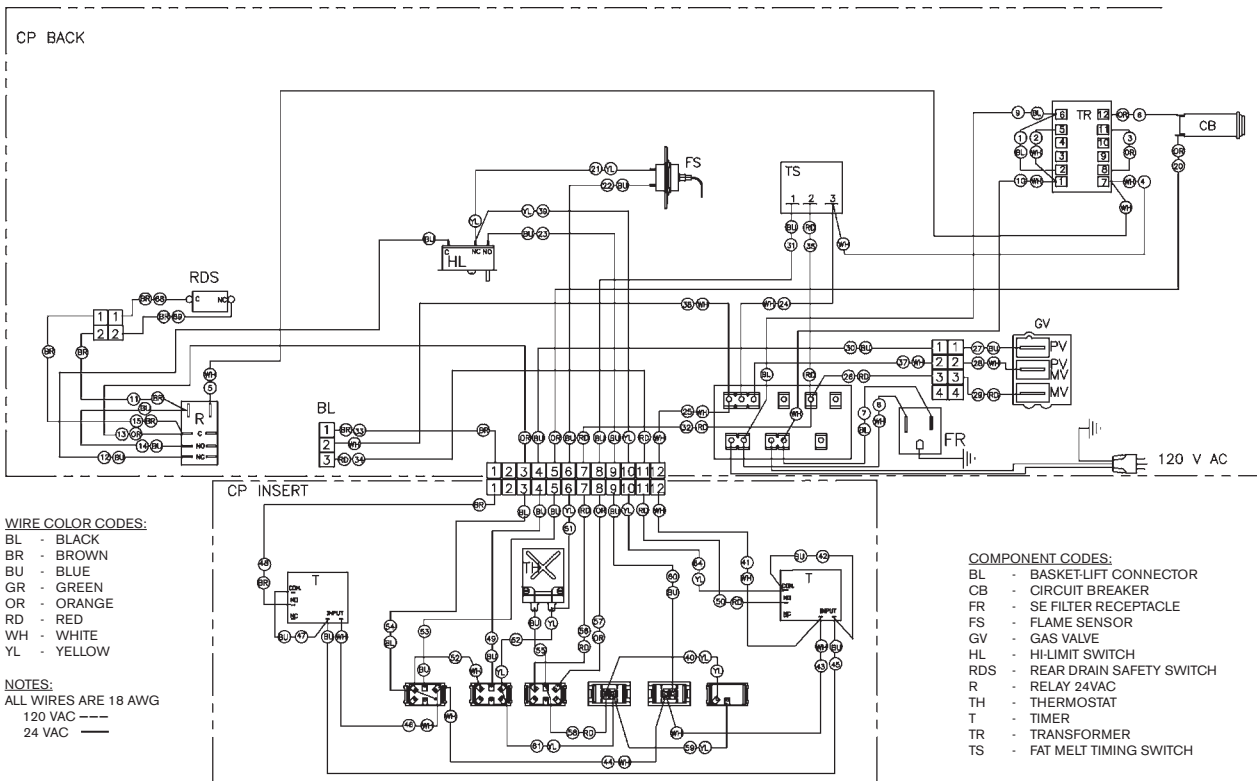

TS 2007 ELECTRICAL ASSEMBLY - FRONT DRAIN

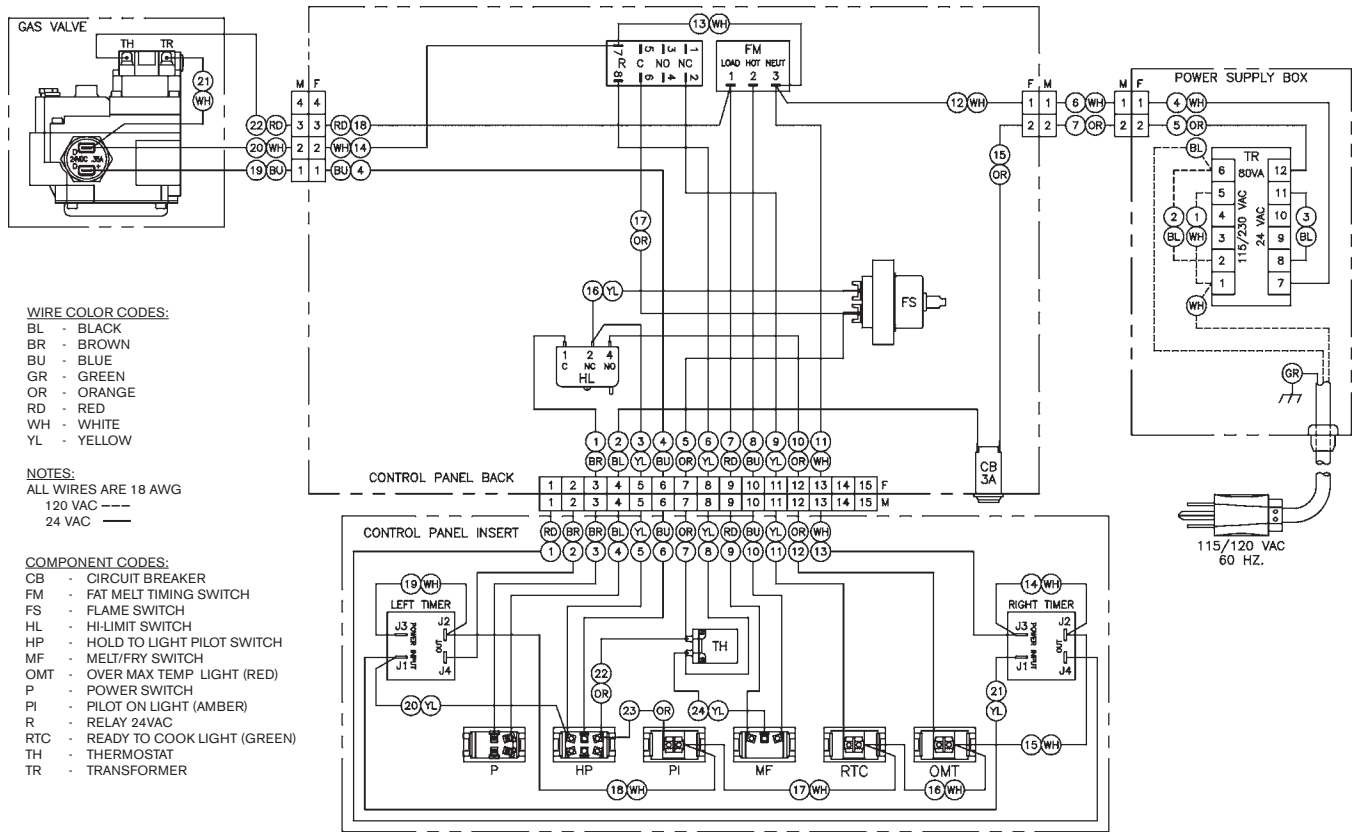

TS 2007 ELECTRICAL ASSEMBLY WITH SAFE & EASY® FILTER

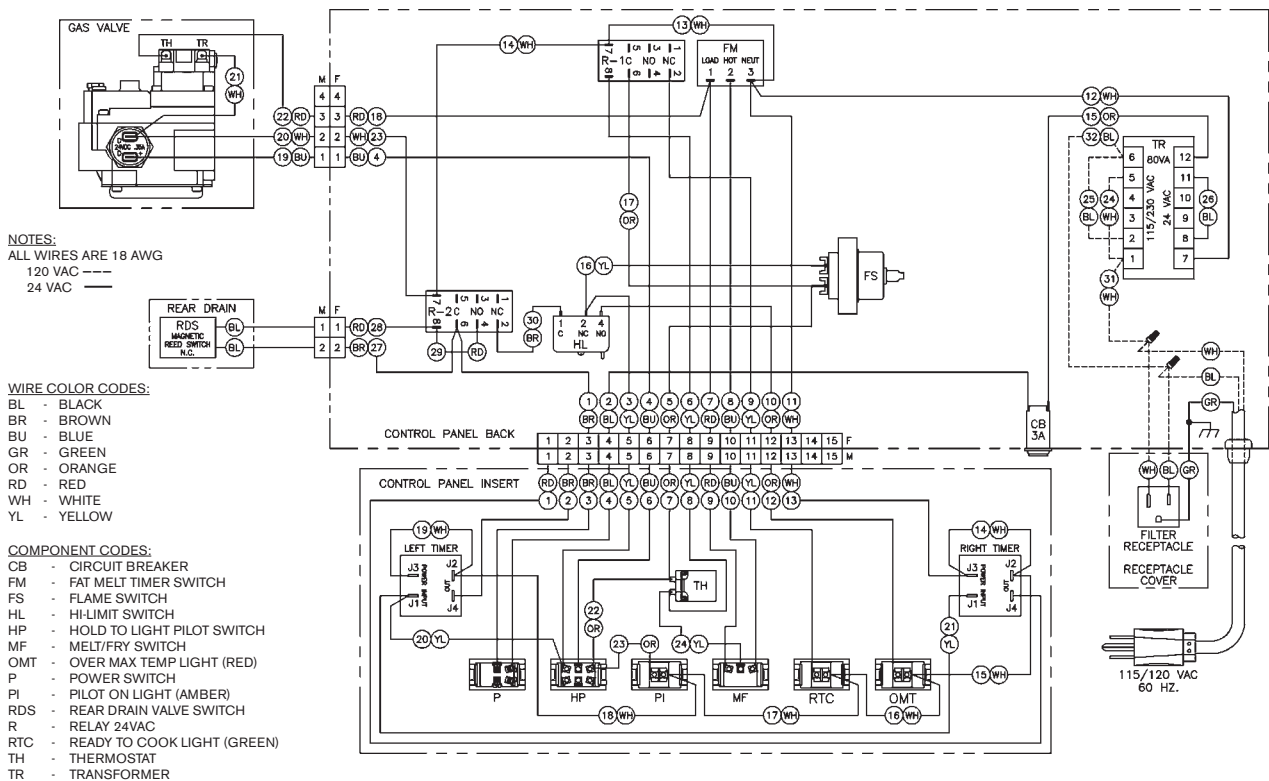

TS 2007 ELECTRICAL ASSEMBLY BASKET-LIFT - FRONT DRAIN

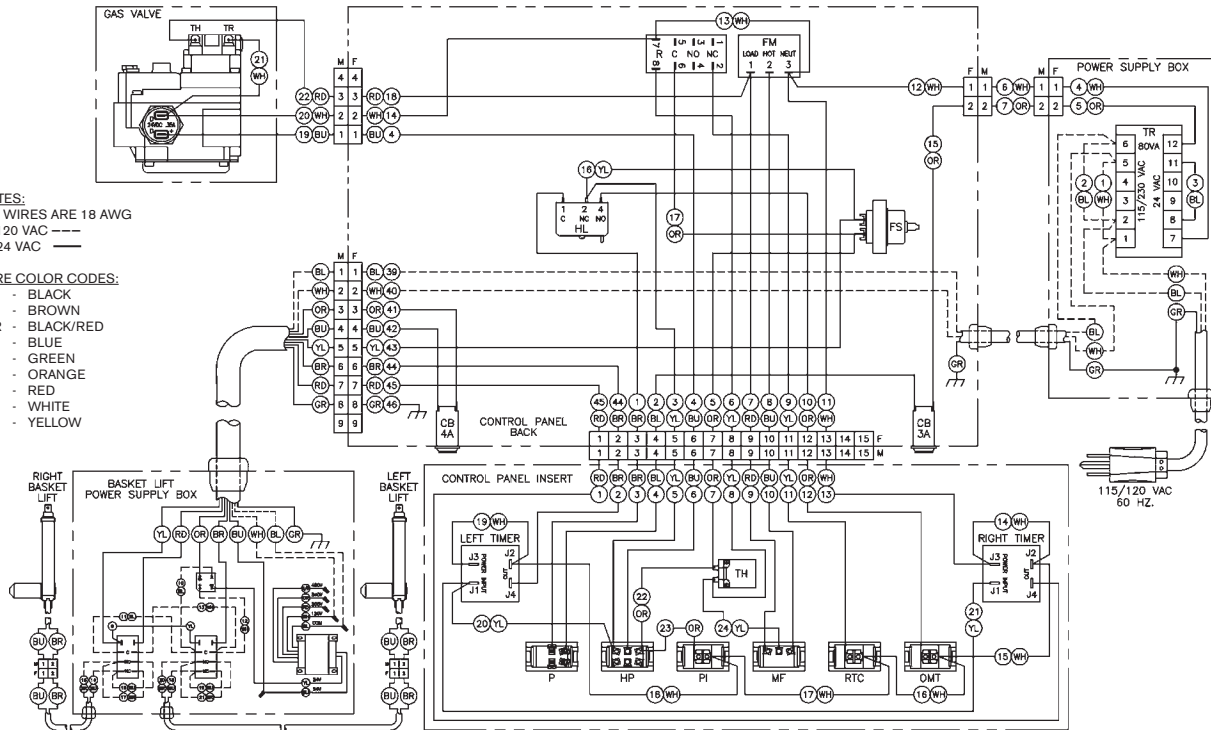

NOTES:
 ALL WIRES ARE 18 AWG
 120 VAC ---
 24 VAC —

WIRE COLOR CODES:
 BL - BLACK
 BR - BROWN
 B/R - BLACK/RED
 BU - BLUE
 GR - GREEN
 OR - ORANGE
 RD - RED
 WH - WHITE
 YL - YELLOW

COMPONENT CODES:

CB - CIRCUIT BREAKER	P - POWER SWITCH
FM - FAT MELT TIMER SWITCH	PI - PILOT ON LIGHT (AMBER)
FS - FLAME SWITCH	R - RELAY 24VAC
HL - HI-LIMIT SWITCH	RTC - READY TO COOK LIGHT (GREEN)
HP - HOLD TO LIGHT PILOT SWITCH	TH - THERMOSTAT
MF - MELT/FRY SWITCH	TR - TRANSFORMER
OMT - OVER MAX TEMP LIGHT (RED)	

TS 2007 ELECTRICAL ASSEMBLY SPARK IGNITION - FRONT DRAIN

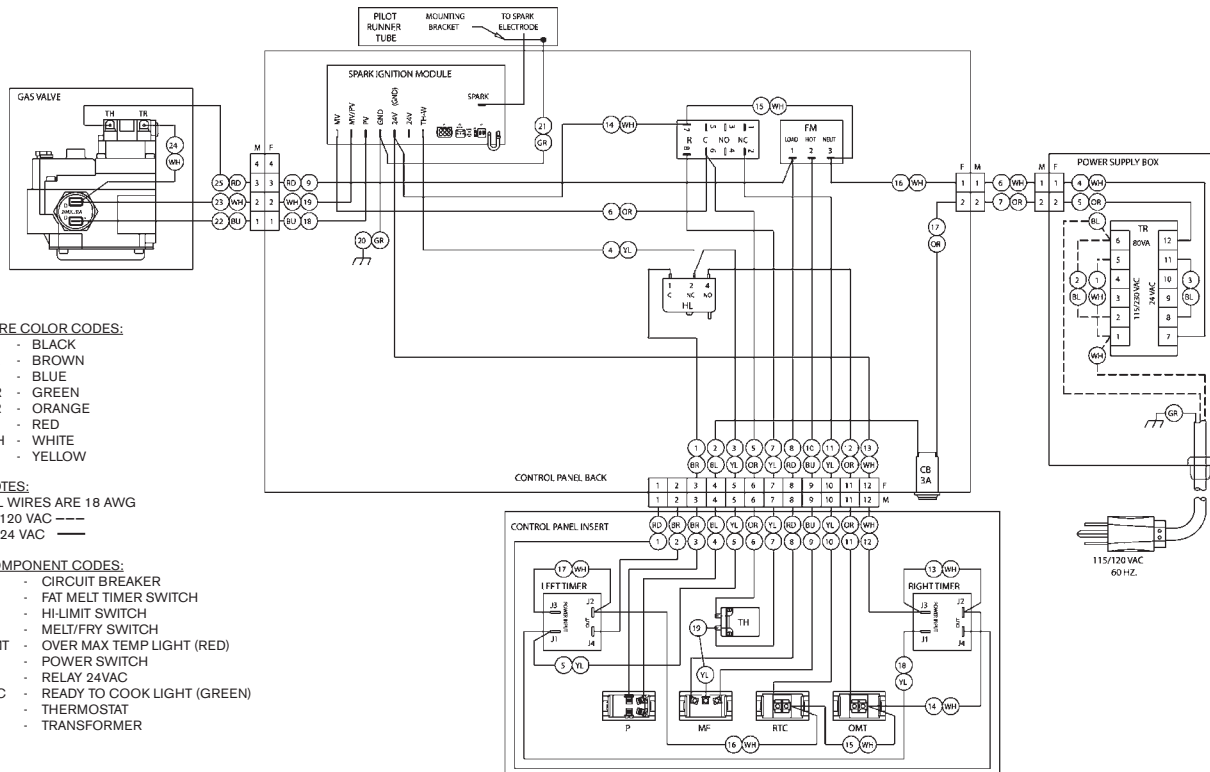

WIRE COLOR CODES:
 BL - BLACK
 BR - BROWN
 BU - BLUE
 GR - GREEN
 OR - ORANGE
 RD - RED
 WH - WHITE
 YL - YELLOW

NOTES:
 ALL WIRES ARE 18 AWG
 120 VAC ---
 24 VAC —

COMPONENT CODES:

CB - CIRCUIT BREAKER	P - POWER SWITCH
FM - FAT MELT TIMER SWITCH	R - RELAY 24VAC
HL - HI-LIMIT SWITCH	RTC - READY TO COOK LIGHT (GREEN)
MF - MELT/FRY SWITCH	TH - THERMOSTAT
OMT - OVER MAX TEMP LIGHT (RED)	TR - TRANSFORMER

TS 2009 ELECTRICAL ASSEMBLY BASKET-LIFT - FRONT DRAIN

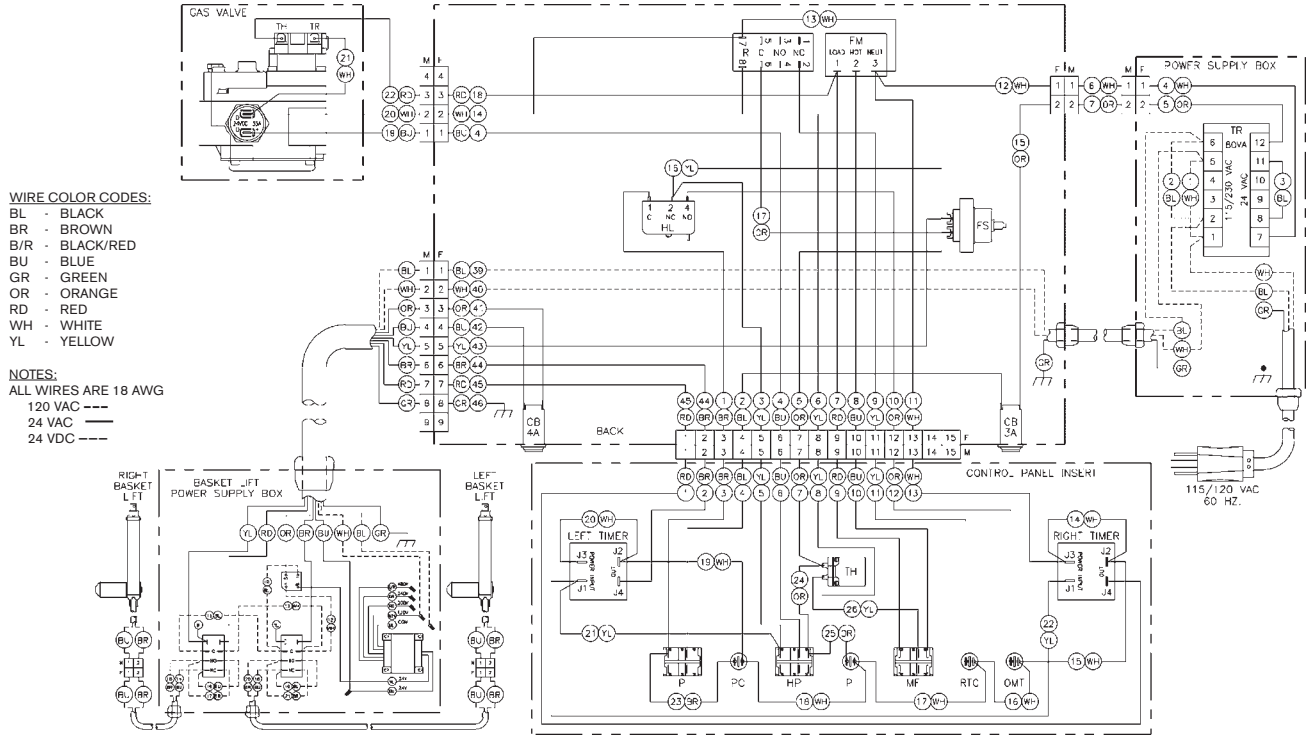

WIRE COLOR CODES:

- BL - BLACK
- BR - BROWN
- B/R - BLACK/RED
- BU - BLUE
- GR - GREEN
- OR - ORANGE
- RD - RED
- WH - WHITE
- YL - YELLOW

NOTES:

- ALL WIRES ARE 18 AWG
- 120 VAC ---
- 24 VAC ---
- 24 VDC ---

COMPONENT CODES:

- | | |
|---------------------------------|-----------------------------------|
| CB - CIRCUIT BREAKER | P - POWER SWITCH |
| FM - FAT MELT TIMER SWITCH | PI - PILOT ON LIGHT (AMBER) |
| FS - FLAME SWITCH | R - RELAY 24VAC |
| HL - HI-LIMIT SWITCH | RTC - READY TO COOK LIGHT (GREEN) |
| HP - HOLD TO LIGHT PILOT SWITCH | TH - THERMOSTAT |
| MF - MELT/FRY SWITCH | TR - TRANSFORMER |
| OMT - OVER MAX TEMP LIGHT (RED) | |

TS 2009 ELECTRICAL ASSEMBLY SPARK IGNITION - FRONT DRAIN

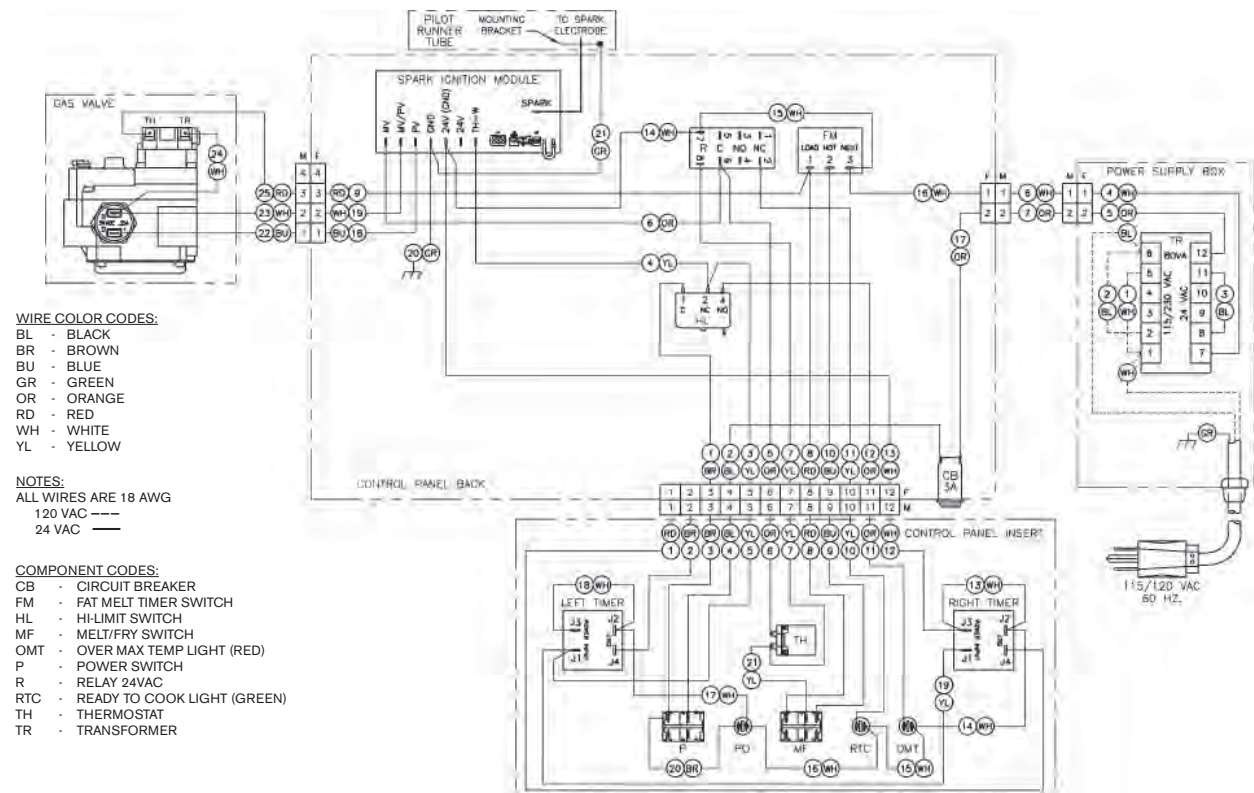

WIRE COLOR CODES:

- BL - BLACK
- BR - BROWN
- BU - BLUE
- GR - GREEN
- OR - ORANGE
- RD - RED
- WH - WHITE
- YL - YELLOW

NOTES:

- ALL WIRES ARE 18 AWG
- 120 VAC ---
- 24 VAC ---

COMPONENT CODES:

- | | |
|---------------------------------|-----------------------------------|
| CB - CIRCUIT BREAKER | P - POWER SWITCH |
| FM - FAT MELT TIMER SWITCH | R - RELAY 24VAC |
| HL - HI-LIMIT SWITCH | RTC - READY TO COOK LIGHT (GREEN) |
| MF - MELT/FRY SWITCH | TH - THERMOSTAT |
| OMT - OVER MAX TEMP LIGHT (RED) | TR - TRANSFORMER |

34x24 TS 2007 ELECTRICAL ASSEMBLY SPARK IGNITION - FRONT DRAIN

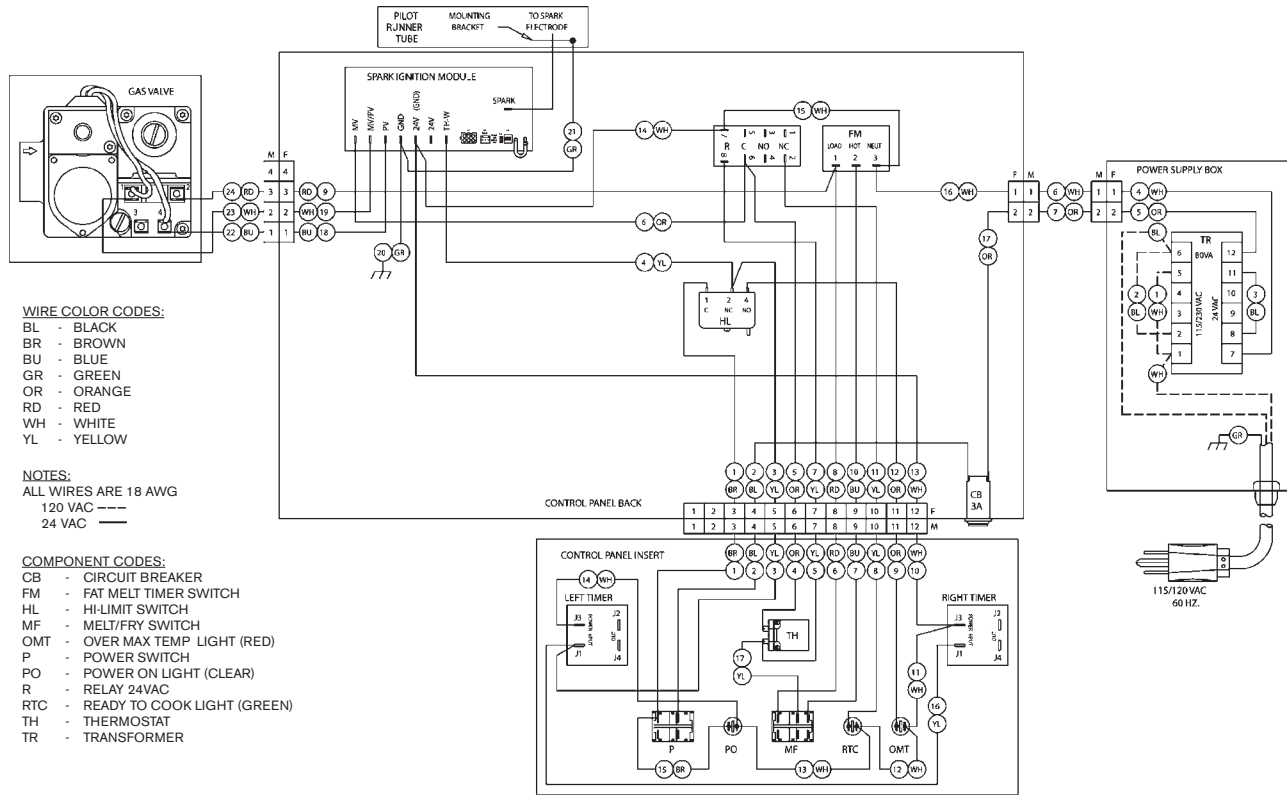

34x24 TS 2007 ELECTRICAL ASSEMBLY - FRONT DRAIN

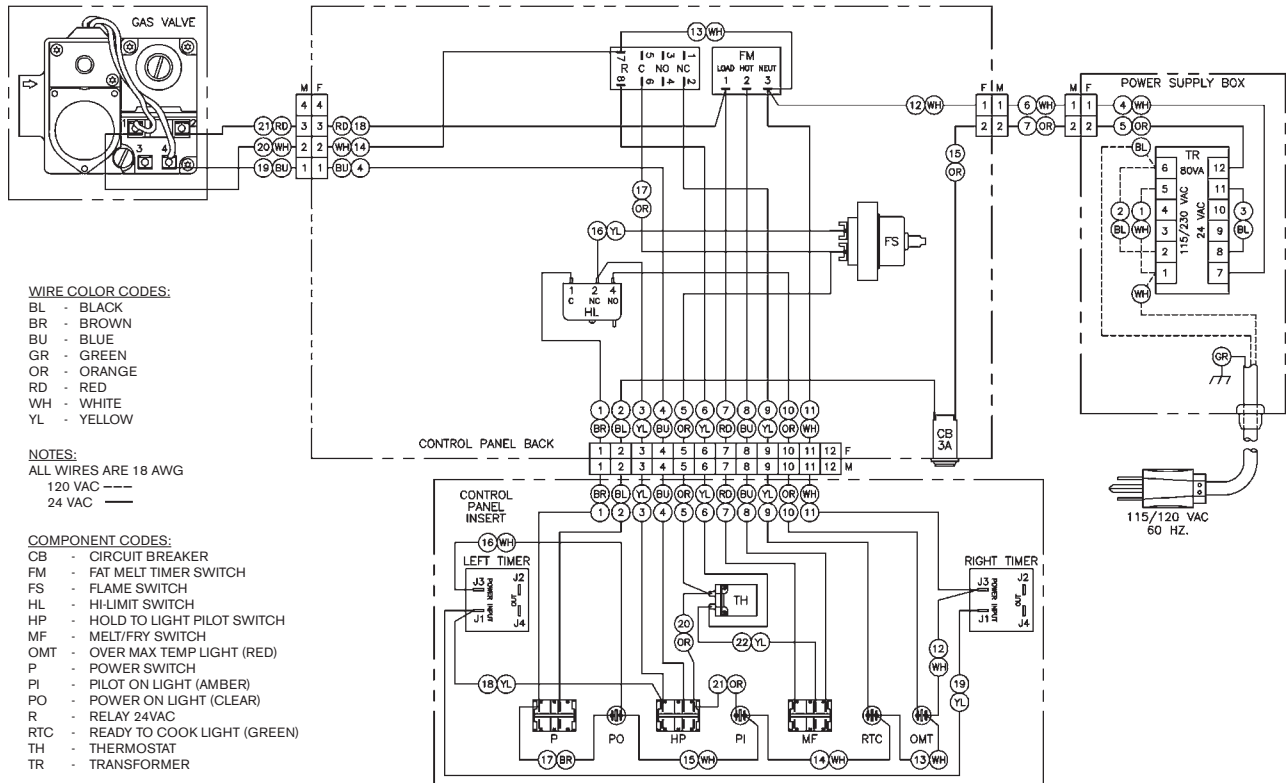

34 x 24 TS 2008 AND ALL TS MODELS 2009 ELECTRICAL ASSEMBLY - FRONT DRAIN

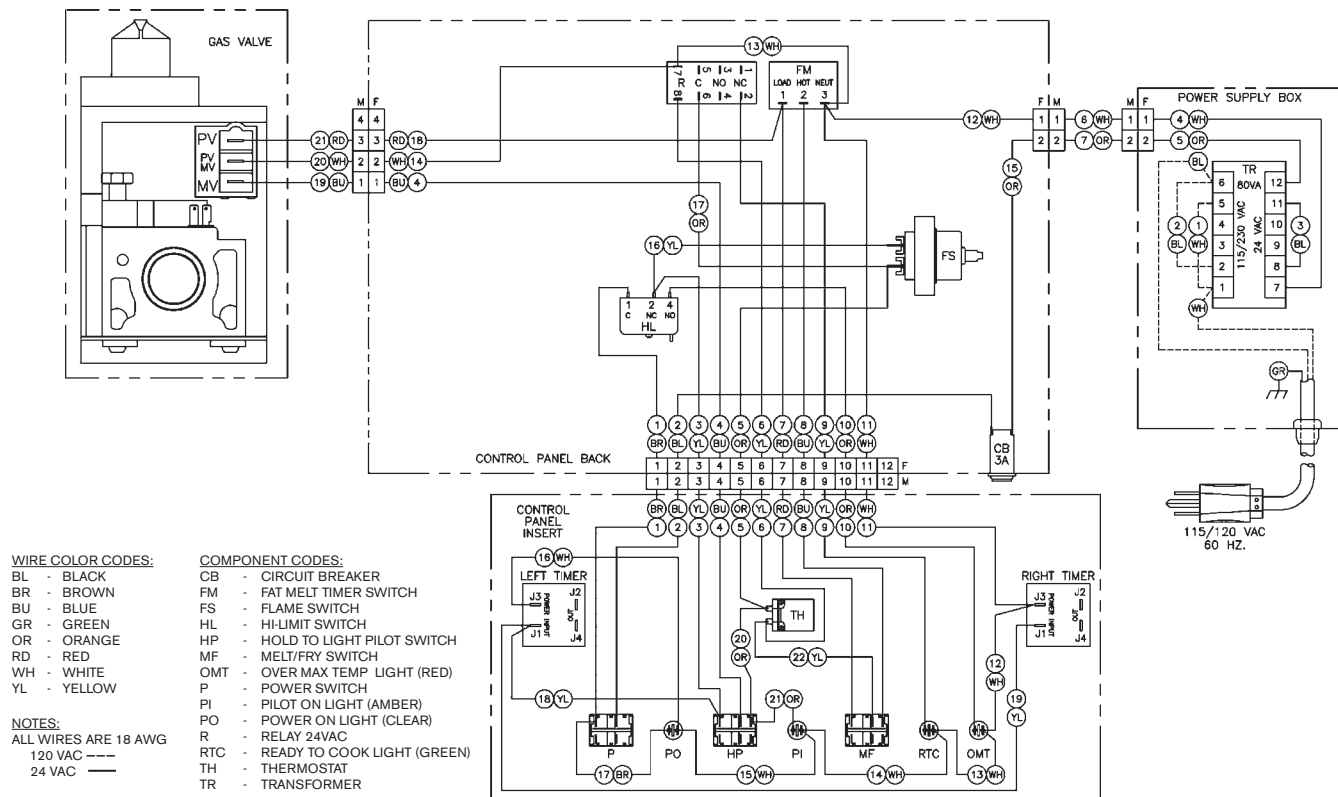

34 x 24 TS 2007 ELECTRICAL ASSEMBLY WITH SAFE & EASY® FILTER

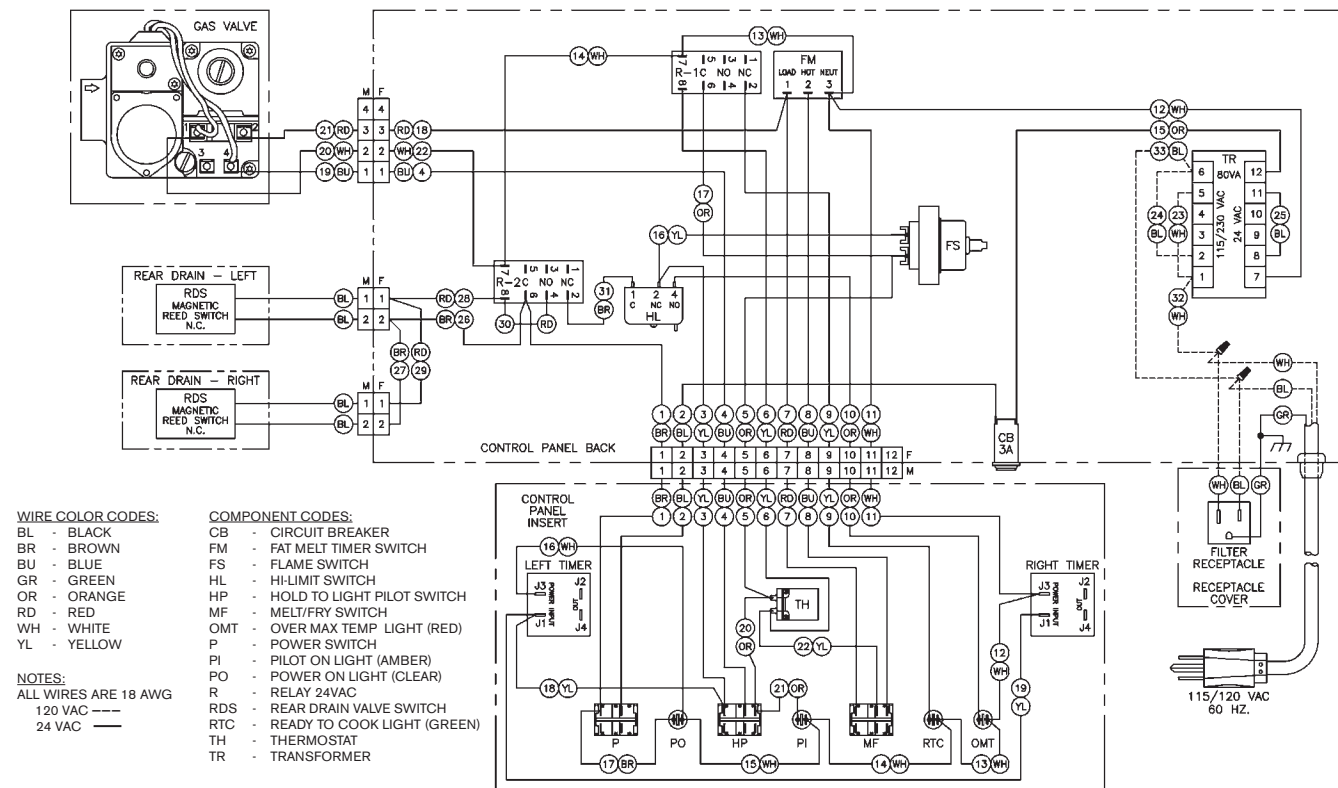

34 x 24 TS 2008 AND ALL TS MODELS 2009 ELECTRICAL ASSEMBLY WITH SAFE & EASY® FILTER

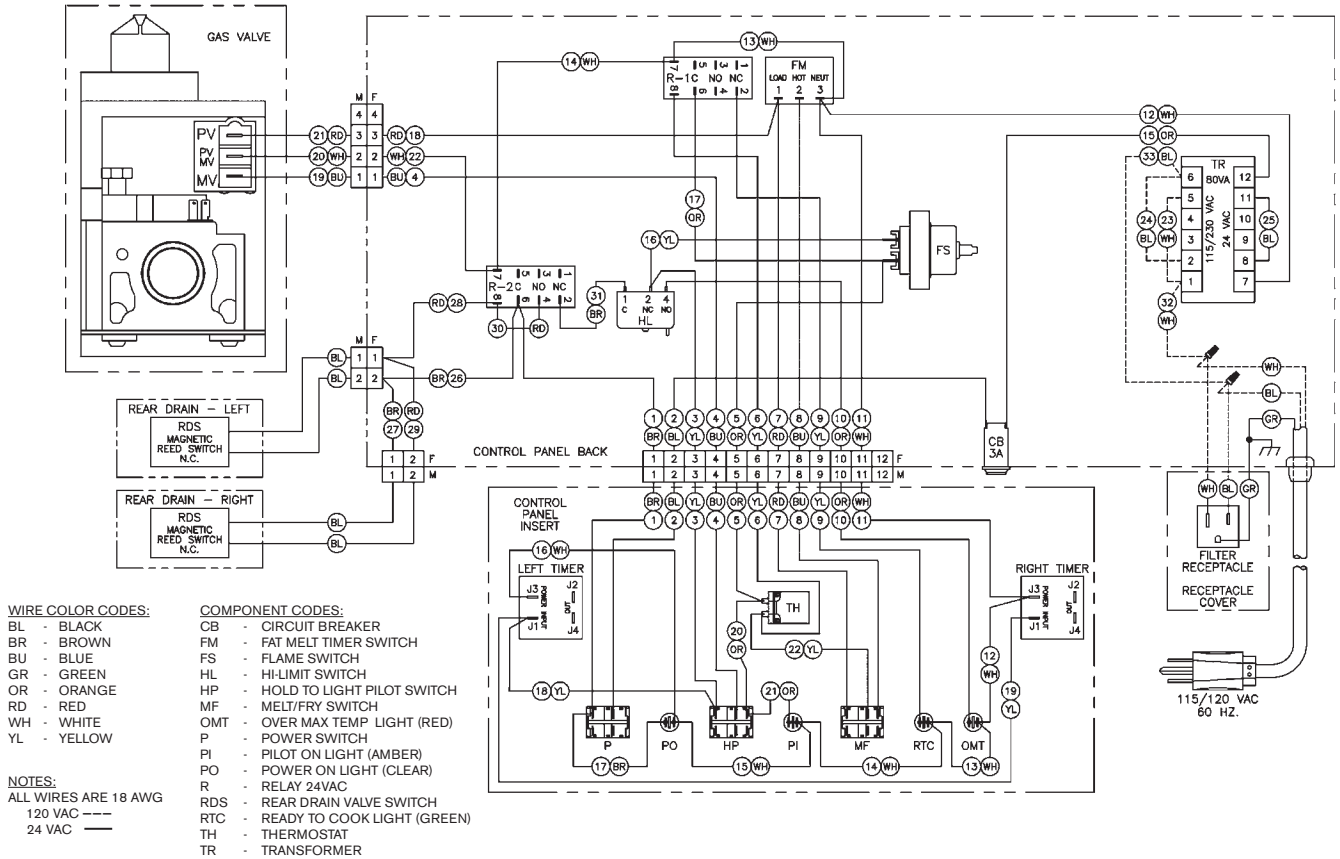

34 x 24 TS 2007 AND ALL TS MODELS 2009 ELECTRICAL ASSEMBLY SPARK IGNITION WITH SAFE & EASY® FILTER

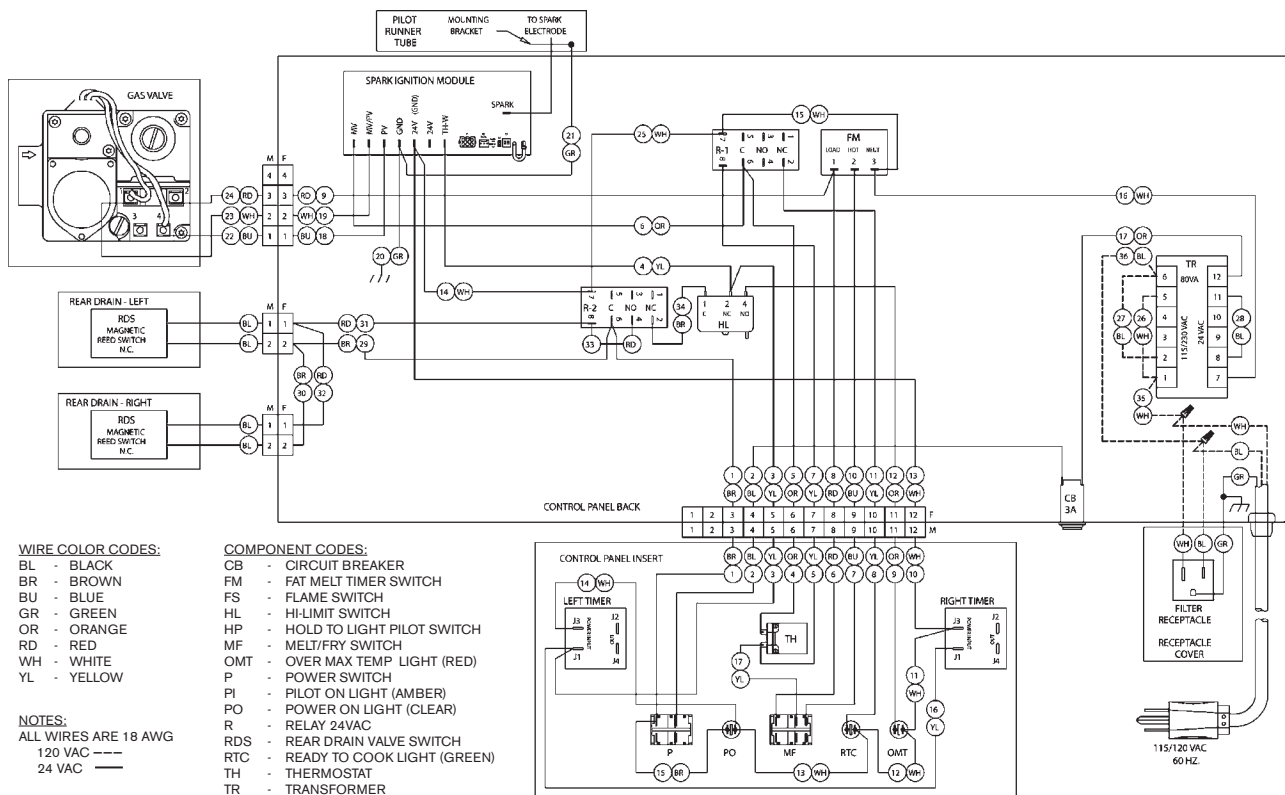

CPU 2007 ELECTRICAL ASSEMBLY - FRONT DRAIN

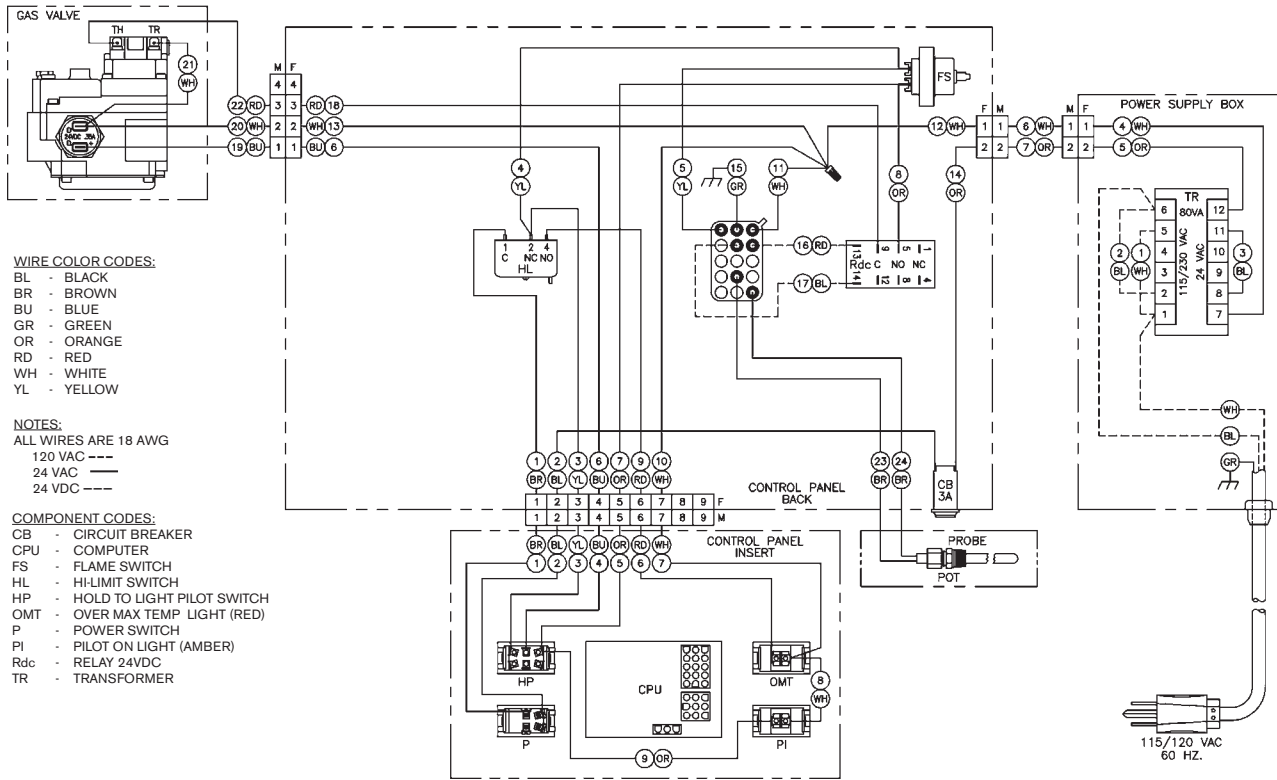

CPU 2007 ELECTRICAL ASSEMBLY WITH SAFE & EASY® FILTER

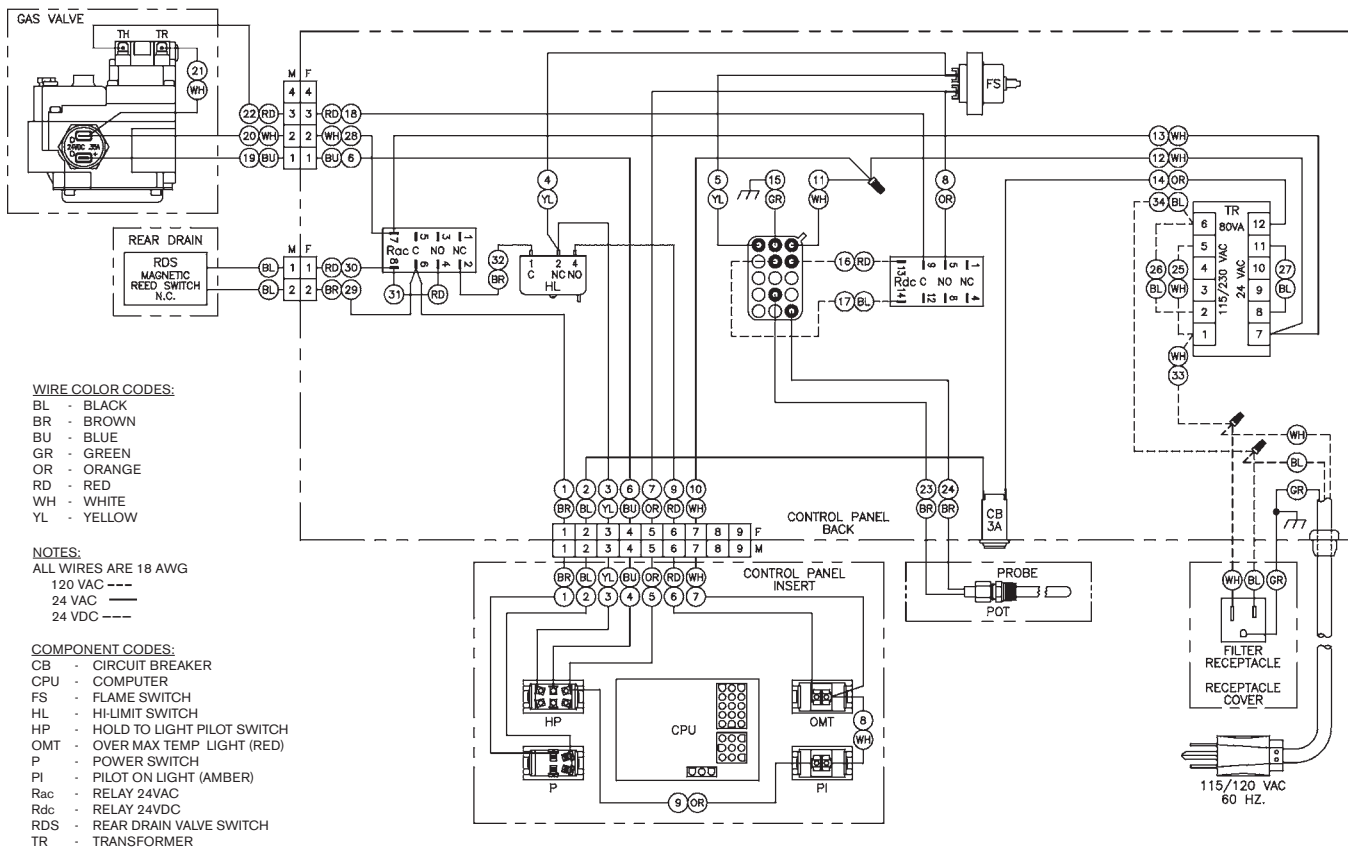

CPU 2007 ELECTRICAL ASSEMBLY SPARK IGNITION - FRONT DRAIN

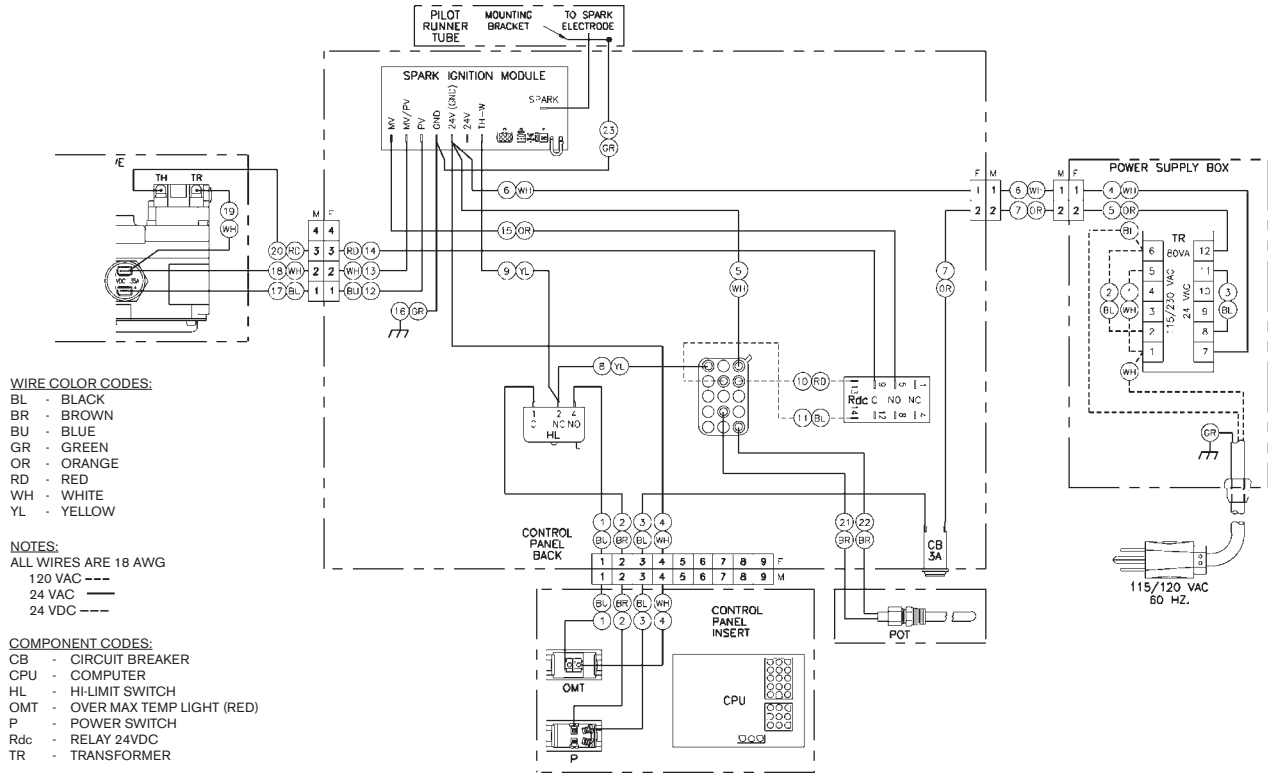

CPU 2007 ELECTRICAL ASSEMBLY SPARK IGNITION WITH SAFE & EASY® FILTER

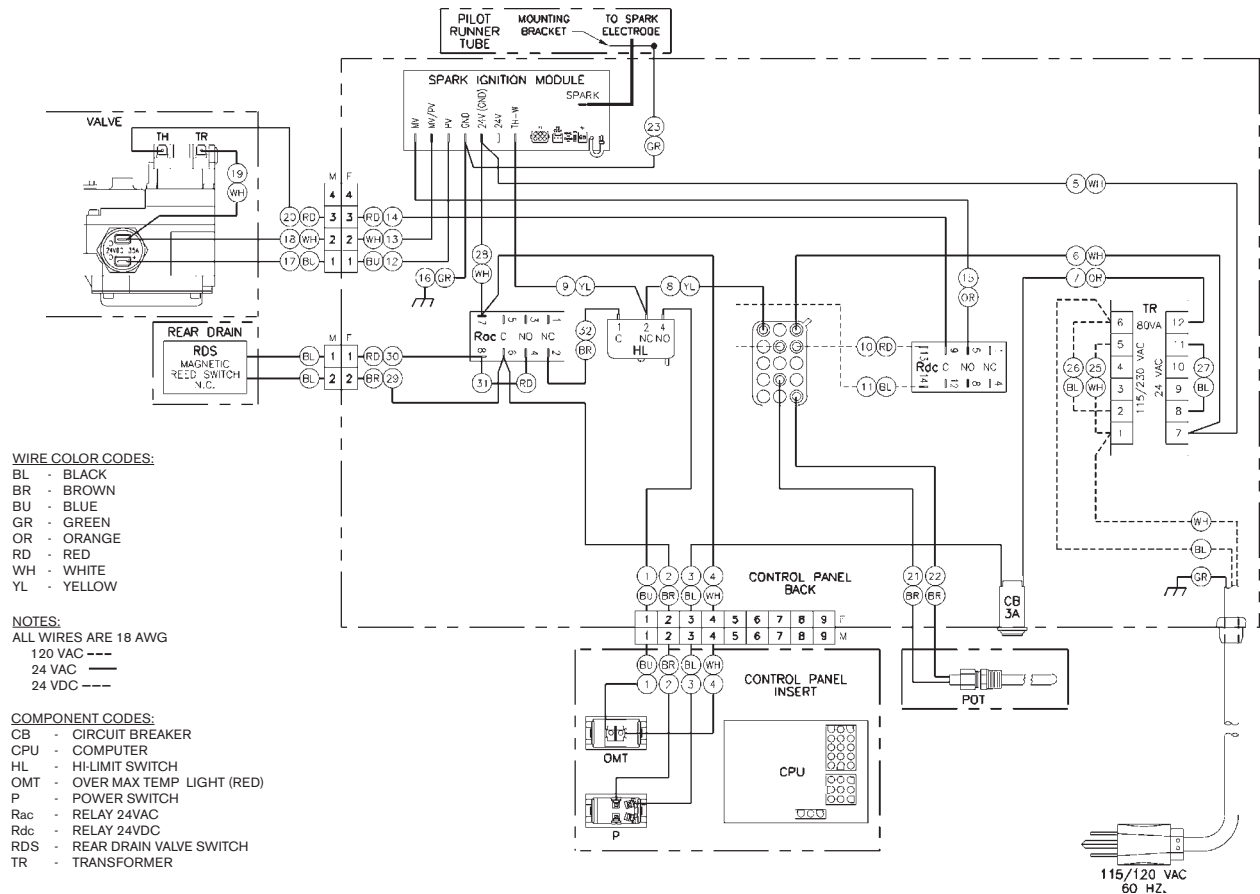

BASKET-LIFT ELECTRICAL ASSEMBLY PRE 2007 (ALL FRYERS)

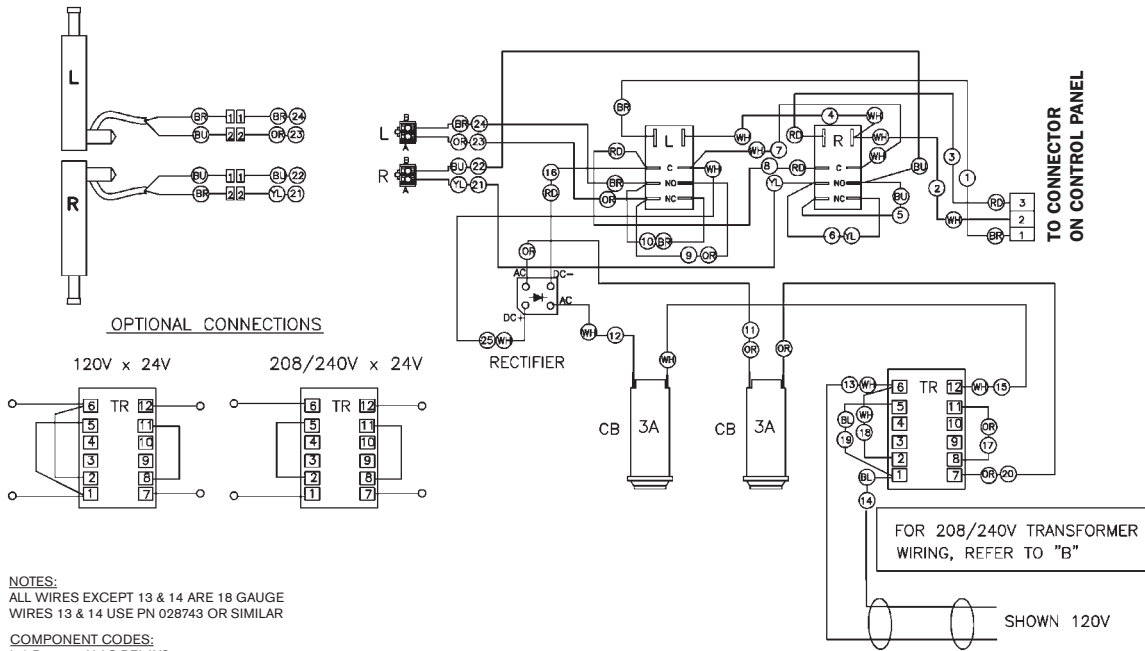

BASKET-LIFT ELECTRICAL ASSEMBLY - SERIES 2007

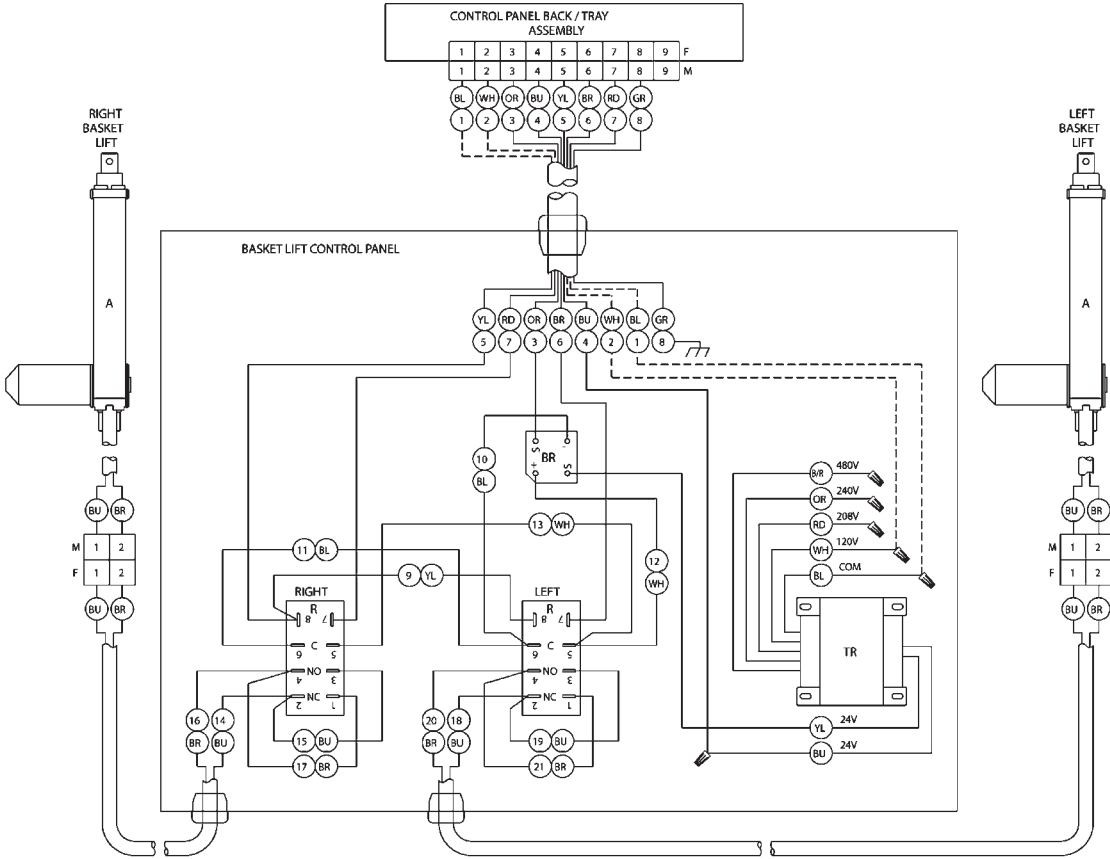

COMPONENT CODES:
 A - ACTUATOR
 BR - BRIDGE RECTIFIER
 R - RELAY 24VAC
 TR - TRANSFORMER (100VA)

WIRE COLOR CODES:
 BL - BLACK
 BR - BROWN
 B/R - BLACK/RED
 BU - BLUE
 GR - GREEN
 OR - ORANGE
 RD - RED
 WH - WHITE
 YL - YELLOW

120 VAC ---
 24 VAC & VDC —

NOTES:
 ALL WIRES ARE 18 AWG
 THIS DIAGRAM SHOWN 120VAC SUPPLY VOLTAGE



WARRANTY

LIMITED WARRANTY

Keating of Chicago, Inc. ("Keating") warrants to the original purchaser, ("Customer"), all new Keating Fryers, Filter Systems, Griddles, Keep Krisp[®], Custom Pasta Systems, Top-Side[™] Cookers, Computer Timers, Fryer & Pasta Vessels and Keating replacement parts ("products") installed after June 1, 1994 to be free of defects in material or workmanship, subject to the following terms and conditions.

LENGTH OF WARRANTY

All products other than Fryer & Pasta Vessels and replacement parts shall be warranted for a period of one year from the date of original equipment installation. Keating replacement parts are warranted for a period of ninety days from the date of installation. Fryer & Pasta Vessels are warranted as described below.

FRYER & PASTA VESSEL WARRANTY

Fryers purchased after June 1, 1994 carry a prorated vessel warranty on defects in materials or workmanship to the Customer based on the following scale:

Time from Installation Date	Fryer Vessel Warranty Credit
13-60 months	100%
61-72 months	80%
73-84 months	60%
85-96 months	40%
97-108 months	20%
109-120 months	10%

The credit for the defective fryer & pasta vessel shall be applied against the cost of the replacement vessel, utilizing Keating's then current price, upon return of the vessel to Keating only during the first 60 months, subject to the limitations described below.

LIMITATIONS OF LIABILITY

In the event of warranty claim or otherwise, the sole obligation of Keating shall be the repair and / or replacement at the option of Keating of the product or component part thereof. Such repair or replacement shall be at the expense of Keating except that the Customer shall pay the following expenses: all freight and labor expense for Keating replacement parts; for all other products, mileage exceeding 50 miles or travel more than one hour, labor costs of more than one person, overtime rates, truck charges, difference between ground and other mode of transportation, and holiday charges. Any repair or replacement under this Limited Warranty does not constitute an extension of the original warranty for any period for the product or for any component or part thereof. Parts to be replaced under this Limited Warranty will be repaired at the option of Keating with new or functionally operative parts. Keep Krisps and Computer Timers must be returned to Keating for warranty repair or replacement. Field repairs of those items are not authorized.

THE LIABILITY OF KEATING ON ANY CLAIM OF ANY KIND, INCLUDING CLAIMS BASED ON WARRANTY, EXPRESSED OR IMPLIED, CONTRACT, NEGLIGENCE, STRICT LIABILITY OR ANY OTHER THEORIES SHALL BE SOLELY AND EXCLUSIVELY THE REPAIR OR REPLACEMENT OF THE PRODUCT AS STATED HEREIN, AND SUCH LIABILITY SHALL NOT INCLUDE, AND CUSTOMER SPECIFICALLY RENOUNCES ANY RIGHTS TO RECOVER, SPECIAL, INCIDENTAL, CONSEQUENTIAL OR OTHER INJURIES TO PERSONS OR DAMAGE TO PROPERTY, LOSS OF PROFITS OR ANTICIPATED PROFITS, OR LOSS OF USE OF THE PRODUCT.

If any oral statements have been made regarding the Keating products, such statements do not constitute warranties and are not part of the contract sale. This Limited Warranty constitutes the complete, final and exclusive statement with regard to warranties.

THIS LIMITED WARRANTY IS EXCLUSIVE AND IS IN LIEU OF ALL OTHER WARRANTIES WHETHER WRITTEN, ORAL, STATUTORY OR IMPLIED, INCLUDING BUT NOT LIMITED TO ANY WARRANTY OF MERCHANTABILITY OR FITNESS FOR PARTICULAR PURPOSE OR WARRANTY AGAINST LATENT DEFECTS.

EXCLUSIONS

The warranties provided by Keating of Chicago, Inc. do not apply in the following instances:

1. Defects arising out of or resulting from improper installation or maintenance, abuse, misuse, modification or alteration by unauthorized service personnel, or any other condition not attributable to a defect in material or workmanship. Proper installation and maintenance are the responsibility of the installer and Customer, respectively. Proper installation and maintenance procedures are prescribed by the Keating Service Manual.
2. In the event that the product was damaged after leaving the factory due to flood, fire, other acts of God or accident, damaged during shipment should be reported to the carrier and is not the responsibility of Keating.
3. In the event the serial number or rating plate has been removed from the product or altered.
4. On parts which would normally be worn or replaced under normal conditions, including but not limited to electric bulbs, fuses, interior and exterior finishes, gaskets and radiants.
5. With regard to adjustments and calibrations such as leveling, tightening of fasteners or plumbing connections, improper gas pressure or improper electrical supply, the checking of and changes in adjustment and calibrations are the responsibility of the installer. Proper installation procedures are prescribed by the Keating Service Manual.
6. In the event of unauthorized repairs or alterations to the Keating product.
7. With the use of sodium chloride in pasta vessels or harsh chemicals in fryer or pasta vessels.
8. Installation in Household.

OTHER TERMS AND CONDITIONS

The Customer must provide proof of purchase from Keating.

This Limited Warranty is valid in the 50 United States, its territories, and Canada, and is void elsewhere. Keating products are sold for commercial use only. If any Keating product is sold as a component of another product or used as a consumer product, such Keating product is sold As Is without any warranty.

If any provision of this Limited Warranty is held to be unenforceable under the law of any jurisdiction, such provision shall be inapplicable in such jurisdiction, and the remainder of the warranty shall remain unaffected. Further in such event, the maximum exclusion or limitation allowable under applicable law shall be deemed substituted for the unenforceable provision.

This Limited Warranty shall be governed by and construed in accordance with the laws of the State of Illinois.

TO SECURE WARRANTY SERVICE

All repair services under this Limited Warranty must be authorized by Keating or performed at Keating. Authorization may be obtained by calling 1-800-KEATING within the Continental United States, Alaska, Hawaii, Puerto Rico and Canada during normal business hours (8 a.m. through 5 p.m. Central Time, Monday through Friday). When calling, please have the following information available: (1) name, address and telephone number of the Customer; (2) location of product, if different; (3) name, model number and serial number of the product; (4) installation date; and (5) description of defect. Keating will then issue a service authorization work order number to one of its approved independent servicing organizations, or request the product or part be shipped to Keating for repair or replacement, as appropriate. Any defective part subject to a claim under this Limited Warranty must be shipped freight prepaid to Keating for testing and examination. Keating's decision as to the cause and nature of any defect under this Limited Warranty shall be final.

■ **SERVICE INFORMATION:**

If you have a service related question call **1-800-KEATING**.
Please state the nature of the call; it will ensure speaking with the appropriate person.

Have your serial and model number available when ordering parts.

As continuous product improvement occurs, specifications may be changed without notice.

.....
KEATING LIMITED WARRANTY CARD

PLEASE COMPLETE AND MAIL AT ONCE--WARRANTY IS NOT IN EFFECT UNTIL CARD IS RETURNED, OR COMPLETE THE WARRANTY CARD ON OUR WEBSITE FOR YOUR CONVENIENCE.

COMPANY:

ADDRESS:

CITY: _____ STATE: _____ ZIP CODE: _____

DEALER NAME:

DATE OF PURCHASE: _____ INVOICE #: _____

SERIAL #: _____ MODEL: _____

FRYER GRIDDLE CUSTOM PASTA
 FILTER SYSTEM TOP-SIDE COOKER HOTPLATE

I HAVE READ THE INSTALLATION AND OPERATING INSTRUCTIONS.

SIGNED: _____ DATE: _____



KEATING OF CHICAGO, INC.
8901 West 50th Street
McCook, IL 60525-6001

1-800-KEATING
PHONE: 708-246-3000
FAX: 708-246-3100

Serving Those Who Serve the Very Best®